

20A Wired-In Filter

XPF

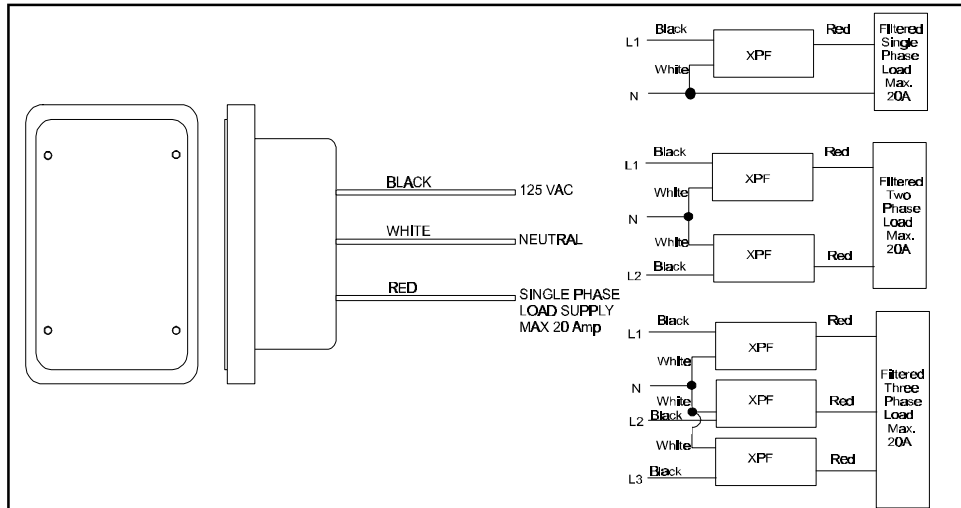

Electrical devices such as TV, VCR, stereo, low voltage power supplies, computers, monitors and power/surge protection strips all have a tendency to "dump" electrical noise on the power lines.

Because line carrier products use the power lines as a communications path they are susceptible to interference. When noise is placed on the power lines it can attenuate, corrupt and/or block the signals being transmitted or received over the entire house.

Typically noise will cause intermittent operation of the receivers. An example would be if you can turn on a light from a transmitter but cannot turn it off from the transmitter or you can turn off a receiver but cannot turn it on. The offending device does not even have to be turned on, because a TV or computer still has their power supplies on the power line when they are turned off.

Noise on the power line is solvable. The proper way to trouble shoot for noise is to use an XPTT Test Transmitter and an XPTR Signal Strength Indicator. The XPTT is plugged in at the transmission point where it will transmit a constant line carrier "P1" on/off command. Taking the XPTR you go from outlet to outlet in the home and take a signal strength reading.

The XPTT transmits a 2V signal and the XPTR can detect from 2V down to 25mV. The lowest possible signal that can make a module respond properly is 100mV. As you go around the structure and you see a fluctuation in the signal you may have detected a noise-producing device. While leaving the XPTR plugged in you can systematically unplug a device (TV, VCR, computer or low voltage lighting power supply) and see if you detect any change in the signal amplitude.

PLUG-IN FILTER

When you see a signal increase upon unplugging a device, then you have detected an offending device. Now all that you have to do is purchase an XPPF plug in filter (not shown). The XPPF is plugged into the wall where the offending device was plugged in and then plug the device into the XPPF. The X10 signal will now pass freely through the electrical system without the noise, blocked by the XPPF, passing onto the power line.

WIRE-IN FILTER

If the offending device is a hard-wired device, shutting off its breaker is necessary to "unplug" it from the system. Then an XPF Wired-In Filter can be installed between the switch and the offending device OR at the breaker panel before that circuit.

Installing the XPF:

1. Shut off the breaker attached to the "offending device".
2. Disconnect the 120VAC supply from the offending device.
3. Connect the 120VAC to the Black lead of the XPF.
4. Connect the White Lead from the XPF to Neutral.
5. Connect the Red lead from the XPF to the offending device. This supplies power to the device.

Note: make sure that you do not exceed the 20A load rating.