

The ELK-SWB14P is a universal plastic enclosure that accommodates accessories, circuit boards, shelves, brackets, and wiring modules. Unlike metal enclosures, the ELK-SWB14P will not interfere with RF signals, making it a ideal for E27 control installations that include a WiFi adapter, wireless receiver, and/or Z-Wave module. The ELK-SWB14P is designed to be surface mounted.

1. Remove any conduit knockouts prior to mounting the box.
2. Position the box against the wall making sure that it is level. Install a #10 screw (not included) in the upper left and right key shaped mounting holes. Make any adjustments to the box level and then install two more screws in the lower 2 mounting holes.
3. Pull wires through one or more of the entry holes. The design of the SWB14P allows wires to be organized along the sides.
4. If desired, a one gang electrical "J" box and duplex outlet may be mounted in the large rectangular knockout of the lower flange. Use #6 Flat Head Self-Tapping Screws (not included).

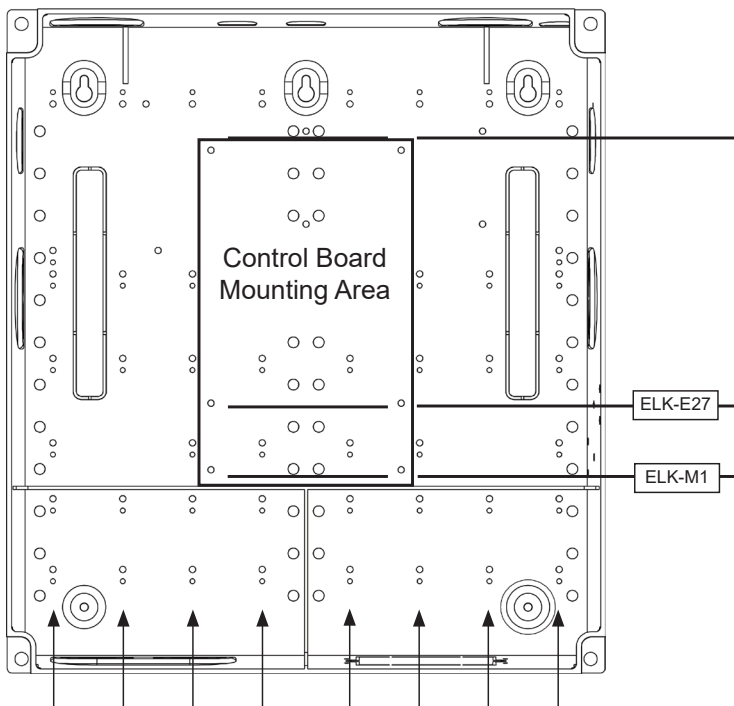

5. ELK-E27 or ELK-M1 control boards can be mounted as shown in the diagram below. Shoulder screws are provided with the control boards for mounting.



Columns of holes for mounting accessory circuit boards.

6. For accessory circuit boards there are 8 columns of repeated 2-hole punch patterns, see diagram. One hole in each pattern is slightly larger than the other. These 2-hole patterns are for plastic Circuit Board Glides (p/n ELK-SWG). The small hole is for a 6/32 type "F" mounting screw and the large hole is for a half-moon shape tab on the bottom of each glide.

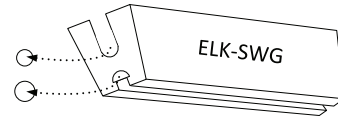

To mount a circuit board, select a pair of 2-hole patterns in the same vertical column that have their larger holes facing one another. The distance between the center of the large holes determines the size (length) of the circuit board that may be mounted. The available mounting lengths in inches are: 3-1/2", 4", 6", 8", 9-3/8", and 11".

Starting at the top, loosely start a 6/32" mounting screw in the small hole of the first selected 2-hole pattern. Place the slotted edge of a circuit board glide under this screw, making sure that the half-moon tab fits into the larger hole and the grooved edge is facing down. Tighten the screw using a long shafted screwdriver. In the second or lower 2-hole pattern loosely start a 6/32" mounting screw. Attach the second circuit board glide using the same procedures. The grooved edge of this glide should face up.

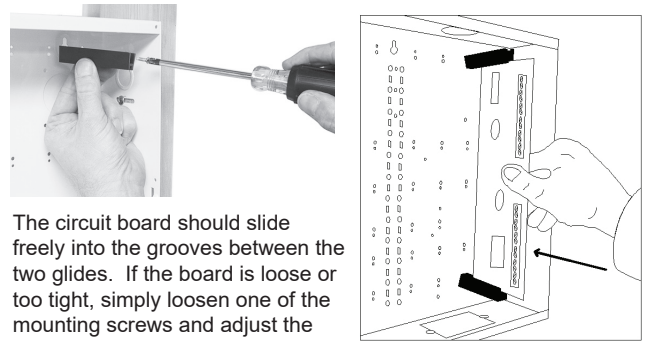

The circuit board should slide freely into the grooves between the two glides. If the board is loose or too tight, simply loosen one of the mounting screws and adjust the glide to assure a good fit.

7. The enclosure cover is attached with the supplied machine screws; two 12mm screws and two 15mm screws. Using a hand screwdriver, install the 12mm screws in the top holes of the enclosure, driving each screw approximately 7mm deep. Hang the cover on the screws using the keyholes in the upper corners of the cover. Install the 15mm screws in the bottom corners. Tighten all four screws to secure the cover.

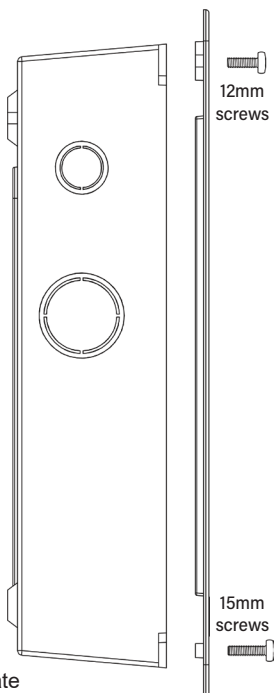

Features & Specifications

- Knockouts on left and right for wire entry into back of box
- Conduit knockouts: 1/2", 3/4", 1 1/4"
- Enclosure size: 14.125" W x 15.75" H x 3.75" D
- Cover size: 16"W x 17.25"H

Accessories For SWB14P

- | | |
|-----------|------------------------------------|
| ELK-SWG | Circuit Board Glides (2) |
| ELK-SWP3 | 3" Multipurpose Adapter Plate |
| ELK-SWP4 | 4" Multipurpose Adapter Plate |
| ELK-SWS | Battery Shelf |
| ELK-SWNS1 | Nylon Standoffs for SWP3/SWP4 (10) |