

Instructions for WatchOUT DT/PIR Accessory Installation

Pole Adaptor Instructions (RA300P0000A)

<ol style="list-style-type: none"> 1. Open WatchOUT front cover. (Unlock C1, Figure 1). 2. Release internal base (Unlock I1, Figure 2). 3. Open knockouts on external base (Figure 3) <ul style="list-style-type: none"> ➤ W2 / W3: Wire entry knockouts. ➤ P1-P4: Pole connection knockouts to external base. ➤ T7: Optional back tamper knockout 4. Move back tamper on the internal base to the lower right side (Figure 4) 	<ol style="list-style-type: none"> 5. Rest clamps ② and ③ from both sides of the pole and secure the 4 screws and washers ① through knockouts P1-P4 through <u>external holes</u> on the metal bracket (Figure 5). 6. Insert external wires through external base W2, W3. (Figure 3) 7. Insert external wires and tamper wires through internal base. (Figure 4) 8. Secure internal base to external base (Lock I1, Figure 2). 9. Close the front cover (Lock C1, figure 1) and walk test the detector.
--	--

Conduit Adaptor Instructions (RA300C0000A)

<ol style="list-style-type: none"> 1. Open WatchOUT front cover. (Unlock C1, Figure 1). 2. Release internal base (Unlock I1, Figure 2). 3. Open knockouts on external base (Figure 3) <ul style="list-style-type: none"> ➤ W1: Wires entry knockout. ➤ B1, B2: Conduit adaptor connection knockouts to external base. ➤ T1: Tamper knockout (Used for wall mounting) 4. On the conduit adaptor, remove cable wiring knockout according to the required diameter: 21 mm (0.83 inch) or 16 mm (0.63 inch) (Figure 6) 5. Mount the conduit adaptor as follows: <ul style="list-style-type: none"> ➤ Mounting at 45°: <ol style="list-style-type: none"> a. Remove the corner wall mounting knockouts on the relevant side CL1-CL2 or CR1-CR2 (Figure 7) b. Connect conduit to conduit adaptor c. Secure conduit adaptor to the wall. <p>Note: 45° installation does not support back tamper protection</p>	<ul style="list-style-type: none"> ➤ Wall mounting: <ol style="list-style-type: none"> a. Remove wall mounting knockouts CB1-CB4 (Figure 7) b. Connect conduit to conduit adaptor c. Secure conduit adaptor to the wall d. Insert back tamper extension unit on the top left corner of the conduit adaptor. (CT1, Figure 6). <ol style="list-style-type: none"> 6. Insert external wires through external base W1 (Figures 3,8) 7. Secure external base to conduit adaptor using supplied two small screws (Figure 8) from B1-B2 (Figure 3) to CX1 and CX2 (Figure 7) 8. Insert external wires and tamper wires through internal base (Figure 9) 9. Secure internal base to external base (Lock I1, Figure 2) 10. Close the front cover (Lock C1, Figure 1) and walk test the detector
---	---

Pole + Conduit Adaptors Instructions

<p>Step 1: Attaching the conduit and pole adaptors together</p> <ol style="list-style-type: none"> 1. On the conduit adaptor remove knockouts: <ul style="list-style-type: none"> ➤ Cable wiring knockout according to the required diameter: 21 mm (0.83 inch) or 16 mm (0.63 inch) (Figure 6) ➤ CP1-CP4: Pole mounting knockouts (Figure 7). ➤ CP5 or CP6: Back tamper extension unit (Figure 7). 2. Rest clamps ② and ③ (figure 10) from both sides of the pole and secure the 4 screws and washers ① through Conduit adaptor knockouts CP1-CP4 (Figure 7) and <u>Internal holes</u> on the metal clamps 2 and 3 (Figure 10). <p>Step 2: Attaching the detector to the conduit adaptor</p> <ol style="list-style-type: none"> 1. Open WatchOUT front cover. (Unlock C1, figure 1). 2. Release internal base (Unlock I1, figure 2). 3. On the external base remove knockouts (Figure 3) <ul style="list-style-type: none"> ➤ W1: Wires entry knockout. ➤ B1, B2: Conduit adaptor connection knockouts to external base. ➤ T1: Back tamper knockout 	<ol style="list-style-type: none"> 4. Connect conduit to conduit adaptor. 5. Insert back tamper extension unit on the top left corner of the conduit adaptor (CT1, Figure 6). 6. Insert external wires through external base W1 (Figures 3,8) 7. Secure external base to conduit adaptor using supplied two small screws from (B1-B2, figure 3) to (CX1 and CX2, Figure 6) 8. Insert external wires and tamper wires through internal base. (Figure 9) 9. Secure internal base to external base (Lock I1, Figure 2). 10. Close the front cover (Lock C1, Figure 1) and walk test the detector
---	---

Figure 1:

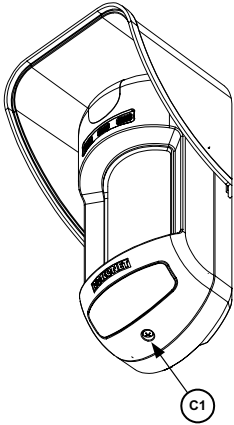

Figure 2:

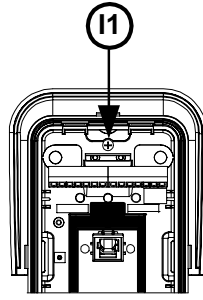

Figure 3:

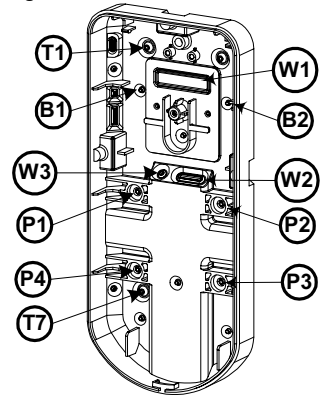

Figure 4:

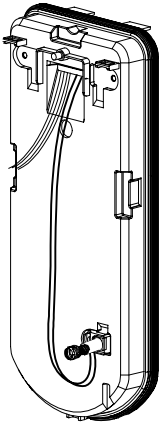

Figure 5:

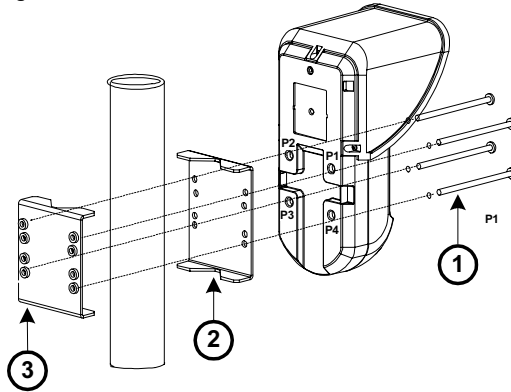

Figure 6:

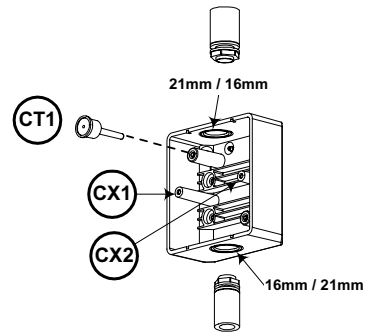

Figure 7:

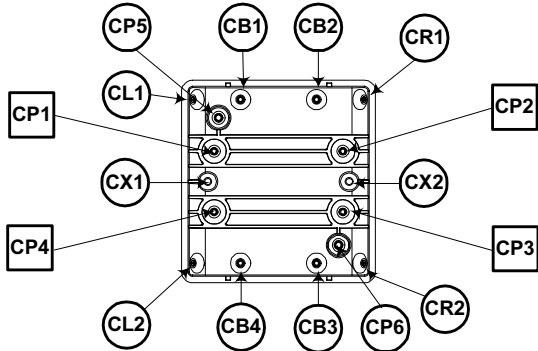

Figure 8:

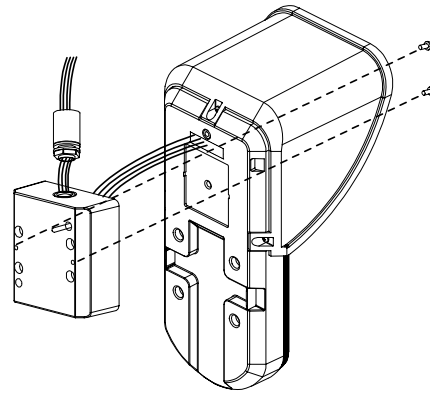

Figure 9:

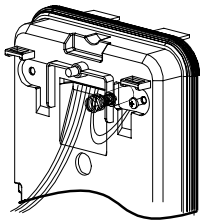

Figure 10:

