

MAKITA AUTOMATIC DRAPERY OPENER SYSTEM

Information Guide



Table of Contents

PART 1: OVERVIEW	3
MOTORS.....*	3
FACTS	4
PART 2: METHODS OF CONTROL	5
INFRARED REMOTE CONTROL.....	5
WALL SWITCH.....	6
TIMER	6
CONTACT CLOSURE INTERFACE	6
PART 3: ADDRESS CHANGES	8
How to CHANGE ADDRESSES	9
BINARY CODES	11
PART 4: ACCESSORIES	12
EXTENDED IR RECEIVING EYE.....	12
SPLITTER.....	12
MODULAR CONNECTING WIRES	12
PART 5: WIRING/APPLICATION DIAGRAMS AND PRODUCT SPEC SHEETS	14
ASSEMBLY DIAGRAM.....	15
SIMULTANEOUS Two MOTOR OPERATION	16
“DAISY-CHAIN” MULTIPLE MOTORS (SIMULTANEOUS OPERATION)	17
MAXIMUM DOUBLE MOTOR SINGLE TRACKS	18
ZZCM101	19
ZZCM301.....	20
SPLITTER.....	21
CONTACT CLOSURE INTERFACE	22
CONNECTING WIRE (ZZ22CW & ZZ42CW)	23
CONNECTING WIRE (ZZ22CW-2 & ZZ42CW-2)	24
WALL SWITCH.....	25
TIMER/INPUT PORT (ZZCM101).....	26
TRACK.....	27
BRACKETS	28

Part 1: Overview

Motors

The Makita Automatic Drapery Opener System offers two different types of motors; the ZZCM101 (Figure 1) which is the “Parent” motor, and the ZZCM301 (Figure 2) which is the “Kid” motor.

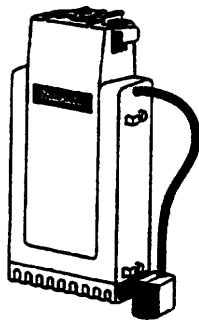

Figure 1

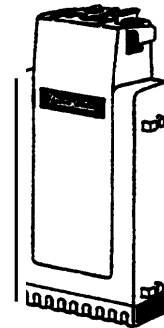

Figure 2

While the motors are identical in power and design, the “Parent” contains the circuitry that allows it to control the command reception and implementation of itself, as well as up to two “Kid” motors. In layman terms, this means that the “Kid” motor(s) will not operate unless connected to the “Parent” motor via the supplied modular wire. The “Parent” motor is the only motor that can receive commands (Open, Close, Stop signals). Once it receives these signals it can send them to the “Kid” motor(s) through the modular wire discussed above, allowing the “Kid” motor(s) to function. The “Kid” motor(s) is controlled separately and will work as if it is independent from the “Parent”. This can mean a lower cost when multiple motors are used in one room since the “Kid(s)” is lower in cost than the “Parent”.

As you can see, Makita provides only two types of motors: “Parent” and “Kid”. This is an important statement since it helps to simplify the understanding of the system.

All of the “Parent” motors (ZZCM101) come from the factory addressed to respond to frequency 1. As such, they can receive and send frequencies 2 and 3 to attached “Kid” motor(s). The “Kid” motor(s) receive their command protocols via low voltage 4 conductor wire with male modular plugs which connect to the female modular port located at the bottom of the motors. The “Parent” motor has three ports: ‘Timer’, “2” and “3”. When a ‘Kid’ motor is attached to the #2 port on the “Parent” motor, it will respond to frequency 2. When attached to #3 it will respond to frequency 3.

While the “Parent” motors come set to address 1 they can be altered to addresses 2-8. “Kids” only know to follow the address of the ‘Parent? For example, if the “Parent” is altered to be address #3 the “Kid(s)” would respond to address #4 and #5 respectively. As such, the maximum number of motors that can be controlled per zone is 10; (“Parent” set to #8 with the ‘Kid(s)” being #9 and #10). This is the key for understanding the theory of address changes for independent control of multiple units in one room or zone.

The ZZCM101 is controlled by a serial data stream sent via remote control, timer, wall switch or contact closure interface. The binary codes that make up the data streams for the various commands can be seen in (Figure 19).

Facts

- Motor plugs directly into standard 110V outlet (no electrician necessary) and clips direct to rod
- 3 year warranty
- UL listed, per ANSI 325-I 985. NEC;NFPA70
- Reliable: In testing over 30,000 openings and closings were achieved; the equivalent of over 40 years of service at twice a day operations
- Timer allows up to 4 opening and closing cycles daily, providing security, energy savings and furniture protection
- Remote control operates up to 33 feet away
- Motor contains thermal overload protector to prevent overheating
- System contains a clutch allowing most draperies to be opened and closed manually
- Track speed is 50 feet per minute
- Infrared signal penetrates most draperies
- Can handle up to a 40 foot window using double motor single track configuration
- System accommodates one way (left or right), center, multiple and reverse operations.
- Each Motor is rated at 60 Lb. of drapery over a 20’ span. By using two motors on a single track (one at each end) the ratings are doubled.
- Designed for pinch pleat drapery

- Installs as easily same as a manual traverse rod
- Same quality and reliability you have come to expect from Makita

Part 2: Methods of Control

The Makita motors can be controlled by the Makita infrared remote, timer, wall switch or contact closure interface. It can also be controlled by emulating the serial data (figure 19) and sending it over a direct connection.

Infrared Remote Control

There are four models of remote controls. The first number after the “RC” (remote control) denotes the number of motors it controls. Example ZZRC30 = 3. While the motors will accept and respond to all ten frequency signals, the remote control is limited to sending only 1 - 6. As such, the maximum number of motors that can be controlled independently using the remote is six per room.



Figure 3



Figure 4



Figure 5



Figure 6

The infrared commands that are sent from the remote are 10 bit serial data streams with no leader codes. The absence of a leader code is somewhat unique to Makita. The binary codes that make up the data streams can be seen in (Figure 19).

Wall Switch

The wall switch works on the same principle as the remote control in that it sends the serial data, but is limited to addresses/frequencies 1 - 3. The wall switch works a maximum of three motors per switch. It is low voltage (5v) and comes with 25' of wire that connects to the "Parent" motor through the timer port. It can be recess mounted or surface mounted using the supplied sub base. The numbering system is the same as remote controls. Example ZZWS20 = 2.

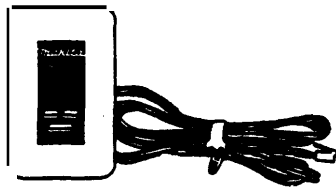

Figure 7

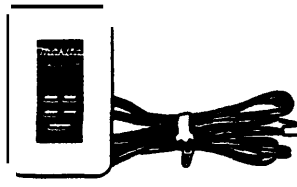

Figure 8

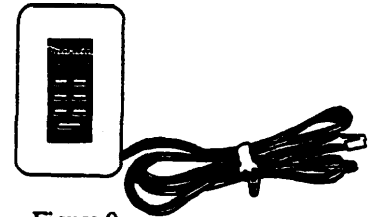

Figure 9

Timer

The timer can be set to open and close the draperies up to four times a day. The timer sends all frequencies (1-10) in sequence, thus controlling any motor(s) (regardless of address) it is attached to. It too, is low voltage and plugs directly into the motor via low voltage modular phone type wire. It provides security, energy savings, furniture protection and controlled plant sunning.

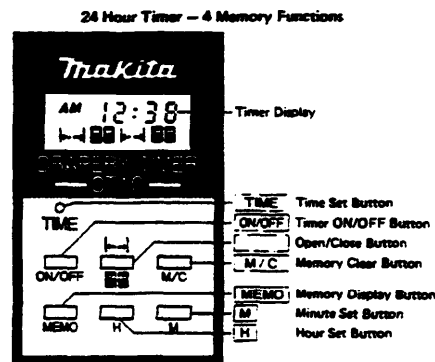

Figure 10

Contact Closure Interface

The Contact Closure Interface (CCI) allows operation of the motors through dry contacts. It takes simple contact closure and converts it to the serial data the motor requires for activation. It can handle momentary or maintained inputs (switch types). It also has home theater masking and multiple preset stop point capabilities. Inputs use 16AWG or smaller wire. Output is a direct connection to the motor using 26AWG phone type wire with RJ9 modular plugs that insert into the "Timer" port of the "Parent". Any or all of the four female modular ports of the CCI can be used. It is not designed to

be used with the “Kid” motor (ZZCM301). Direct connection to the ‘Kid” can damage the CCI.

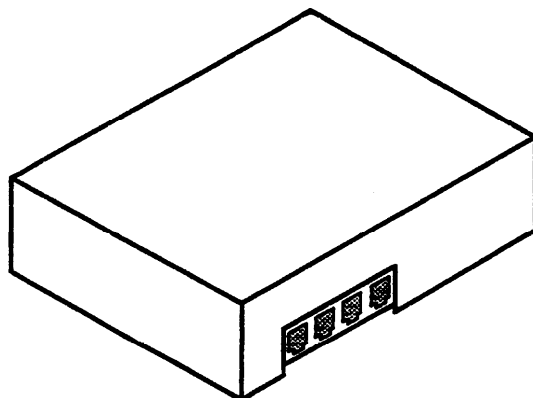

Figure 11

The CCI has the capability to send all ten frequencies to the motor. It also has an *all* feature that sends all frequencies for simultaneous operation of all motors connected to it.

With this interface, virtually any control system can be integrated with the Makiia motors. It will allow the user to work their Makiia Drapery System with any number of companies that incorporate programmable serial data stream or dry contact relay.

For more in-depth information refer to the CCI instruction manual packed with each unit.

The CCI is designed to work in four different switch modes: Momentary, Maintained, Theater and Multiple Presets. Momentary and Maintained refer to switch types; the Theater mode allows for aspect ratio masking and the Multiple Preset mode allows for specific preset stop points for the drapery on the track. The various modes are set using the “mode dip switches”.

Part 3: Address Changes

All of the CM101's come from the factory set to address 1 and will respond to the open, close and stop commands for frequencies 1. They will also accept and pass on the commands for frequencies 2 and 3 to attached 'Kid(s)'

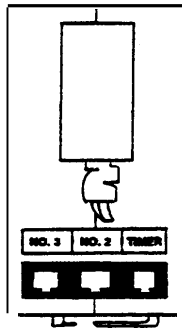

Figure 12

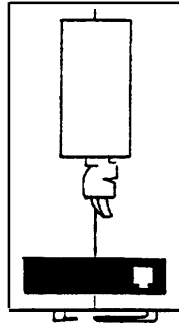

Figure 13

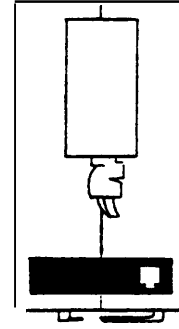

Figure 14

“Parent” motors can be altered to accept commands for up to 10 different frequencies. The highest address a “Parent” can be set to is #8, with attached “Kids” being addresses #9 and #10 respectively. Since the parents come from the factory set at the #1 address, you would only alter them when addresses #2 - #10 are needed. In order to have independent control of multiple motors in one room, it would be necessary to set different addresses for each.

An unlimited number of motors can be controlled by hardwiring to our Contact Closure Interface or Wall Switch. One CCI will control up to 10 motors per control station. By using multiple CCI's and multiple control stations there are no limitations to the number of motors that can be independently controlled. The same is true for our wall switch with one exception; each wall switch (ZZWS30) will independently control up to three motors. By using multiple wall switches, again there is no limitation. In the case of our IR remote you are limited to 6 different addresses per room, although the addresses can be duplicated in other rooms since IR does not penetrate walls.

To gain a full understanding let's use an example. Suppose a customer wants a drape and sheer to be motorized on two separate windows in the same room. He/she would like to have independent control of each drapery rod. This means we would have four motorized draperies, two per window (Figure 15).

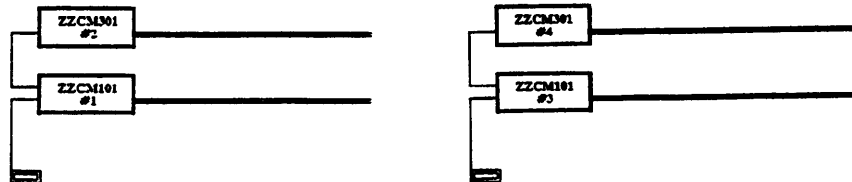

Figure 15

Leaving the motors unchanged from the factory, both ‘Parent’ motors would respond to the #1 command and both kids would respond to the #2 command. To achieve independent control of all motors it becomes necessary to change one of the ‘Parent’ motors to address #3. Why #3? Since the first ‘Parent’ motor responds to frequency #1 and its ‘Kid’ to frequency #2, the next available address is #3. By changing one ‘Parent’ to address #3, the ‘Kid’ attached to it will automatically be a #4 address. We now have independent control of all Motors in the room. For this application, a ZZRC60 remote control would be required to operate all motors.

How to Change Addresses

To alter an address (frequency) on the ‘Parent’ motor (ZZCM101), a connection(s) on the Central Processing Unit must be cut (Figure 17). The picture shows a CPU and an expanded view of the connection(s) that must be cut to change the address. Remember, only the ‘Parent’ motor needs to have its address changed. Regardless of the address the ‘Parent’ motor is set to, the ‘Kid’ motor(s) respond to the next higher address(es).

Steps:

1. Lay motor on its side on a flat surface and remove bottom slide on cover. Open motor by removing all screws and lifting encasement completely off.

Hint: As you remove the top half of the housing, hold the spring loaded locking device at the top of the motor in place. This will prevent having to reinstall and pre-load the spring.

2. Locate Central Processing Board. (Figure 16)

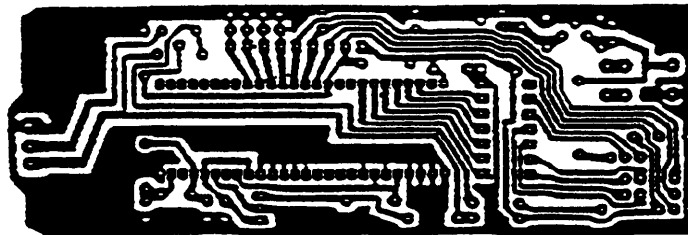

Figure 16

3. Carefully lift board (as far as wires will allow) to give room to work more freely.

4. Locate connections that need to be cut. (Figure 17)

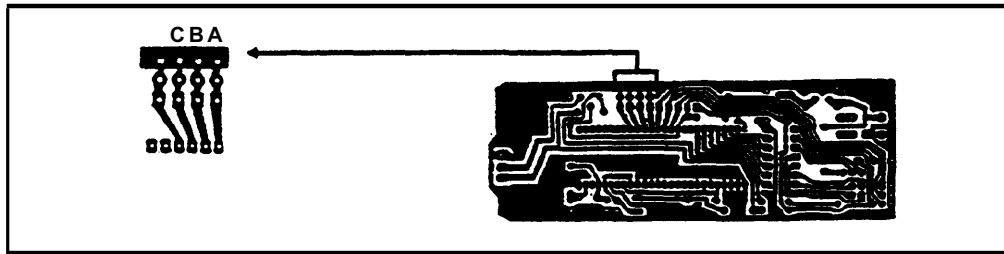

Figure 17

5. Using chart below, find connection(s) to be cut in order to obtain desired address.

ADDRESS	1	2	3	4	5	6	7	8
A	O	X	O	X	O	X	O	X
B	O	O	X	X	O	O	X	X
C	O	O	O	O	X	X	X	X

0 = Leave Connection Intact
X = Cut Connection

6. Using a razor blade or Exacto knife, cut the connection(s) between the terminals for the address you have chose (Figure 18). Multiple passes should be made to ensure the connection is broken. Be careful not to slip and cut other connections.

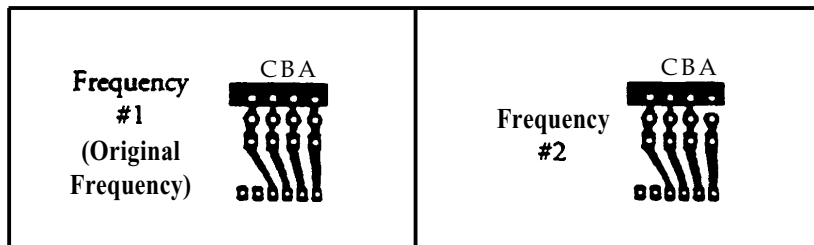

Figure 18

7. Reposition processing board in lower half of case and replace cover. Make sure all wires are clear of encasement and the female modular ports are fitted into their key way to ensure a clean fit.

8. Screw cases back together. Be careful not to over-tighten since the screws are self-tapping and can strip.

9. Test change using remote control

Binary Codes

The ZZCM101 “Parent” motor is controlled by signal sent in 10 bit serial data streams with no leader codes. The data configurations can be seen in binary code format below.

First Pulse Time = 248uS
 Length = 21 mS
 Carrier = 40 KHz

Repeat Count = Continuous
 “0” = 1 milliseconds
 “1 ” = 2 milliseconds

Note: Stop is always the same regardless of Open or Close

Data stream configurations for 10 frequencies (open/close/stop)

Stop	0	1	0	1	0	1	0	0	1	0
Open 1	0	1	0	1	0	0	0	0	1	0
Close 1	0	1	0	0	1	0	0	0	1	0
Open 2	0	1	0	1	1	0	0	0	1	0
Close 2	0	1	0	0	0	1	0	0	1	0
Open 3	0	1	0	0	1	1	0	0	1	0
Close 3	0	1	0	0	0	0	1	0	1	0
Open 4	0	1	0	1	0	0	1	0	1	0
Close 4	0	1	0	0	1	0	1	0	1	0
Open 5	0	1	0	0	0	1	1	0	1	0
Close 5	0	1	0	0	0	0	0	1	1	0
Open 6	0	1	0	1	0	0	0	1	1	0
Close 6	0	1	0	0	1	0	0	1	1	0
Open 7	0	1	0	0	0	1	0	1	1	0
Close 7	0	1	0	0	0	0	1	1	1	0
Open 8	0	1	0	1	0	1	0	1	1	0
Close 8	0	1	0	0	1	1	0	1	1	0
Open 9	0	1	0	1	0	0	1	1	1	0
Close 9	0	1	0	0	1	0	1	1	1	0
Open 10	0	1	0	1	0	1	1	0	1	0
Close 10	0	1	0	0	1	1	1	0	1	0

Figure 19

Part 4: Accessories

All accessories discussed in this section plug into the ‘Timer’ port of the ‘Parent’ motor. When using more than one accessory, the ‘Splitter’ (22654001-A) must be used. While the port is labeled ‘Timer’ a more accurate description is ‘Input’.

Extended IR Receiving Eye

In cases where the IR receiving attached to the ‘Parent’ motor is hidden behind a wall, cornice box, or valance that impedes the signal from reaching it, there are two extended eyes: 5’ lead (Model 22631101-A) and 10’ lead (Model 22631102-A) that plug into the ‘Timer’ port of the ‘Parent’ motor and can be placed anywhere in the room using the supplied Velcro.

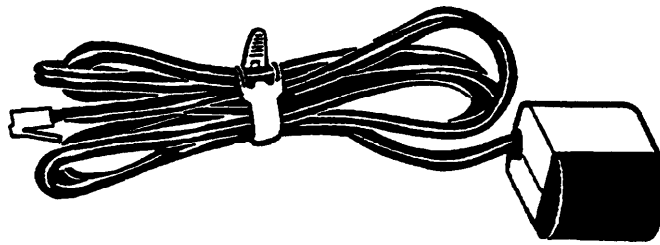

Figure 20

Splitter

The ‘Splitter’ (Model 22654001-A) is needed when using more than one of the following control devices or accessories.

1. Makita Wall Switch
2. Timer
3. Contact Closure Interface
4. Extended IR Receiving Eye
5. Multiple motors on the same frequency for simultaneous operation.

Modular Connecting Wires

Makita offers four different modular connecting wires:

Model **ZZ22CW**: 22’ length, four wire flat phone type, 26AWG (7 X 34) stranded bare copper conductor with RJ9 modular plugs on each end and all four wires connected. (Figure 21)

Model **ZZ22CW-2**: 22’ length, four wire flat phone type, 26AWG (7 X 34) stranded bare copper conductor with RJ9 modular plugs on each end and only two of the four wires connected. (Figure 22)

Model ZZ42CW: 42' length, four wire flat phone type, 26AWG (7 X 34) stranded bare copper conductor with RJ9 modular plugs on each end and all four wires connected. (Figure 21)

Model ZZ42CW-2: 42' length, four wire flat phone type, 26AWG (7 X 34) stranded bare copper conductor with RJ9 modular plugs on each end and only two of the four wires connected. (Figure 22')

Other than the length, the wires look identical. The difference lies in the number of the conductors (wires) that are connected in the RJ9 modular plugs on each end of the wires. The models with (-2) at the end of the model number denotes only two of the conductors (wires) are connected in the plug.

The (-2) models are used when two "Parent" motors are connected for the purpose of simultaneous operation. In this application the +5V wire and the IR disable are not needed (Figure 22). If left connected it may cause damage to the motors.

The models without the (-2) are used for connecting "Parent" motors to "Kid" motors and connections to the CCI (Figure 21)

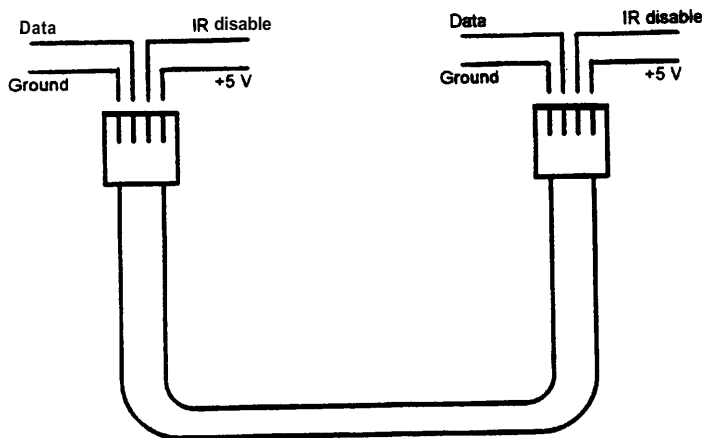

Figure 21

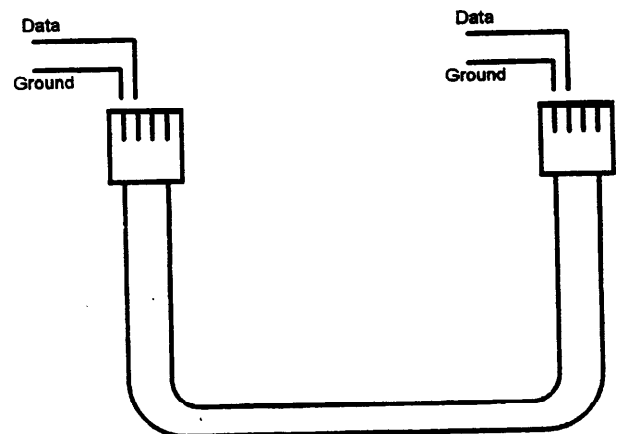
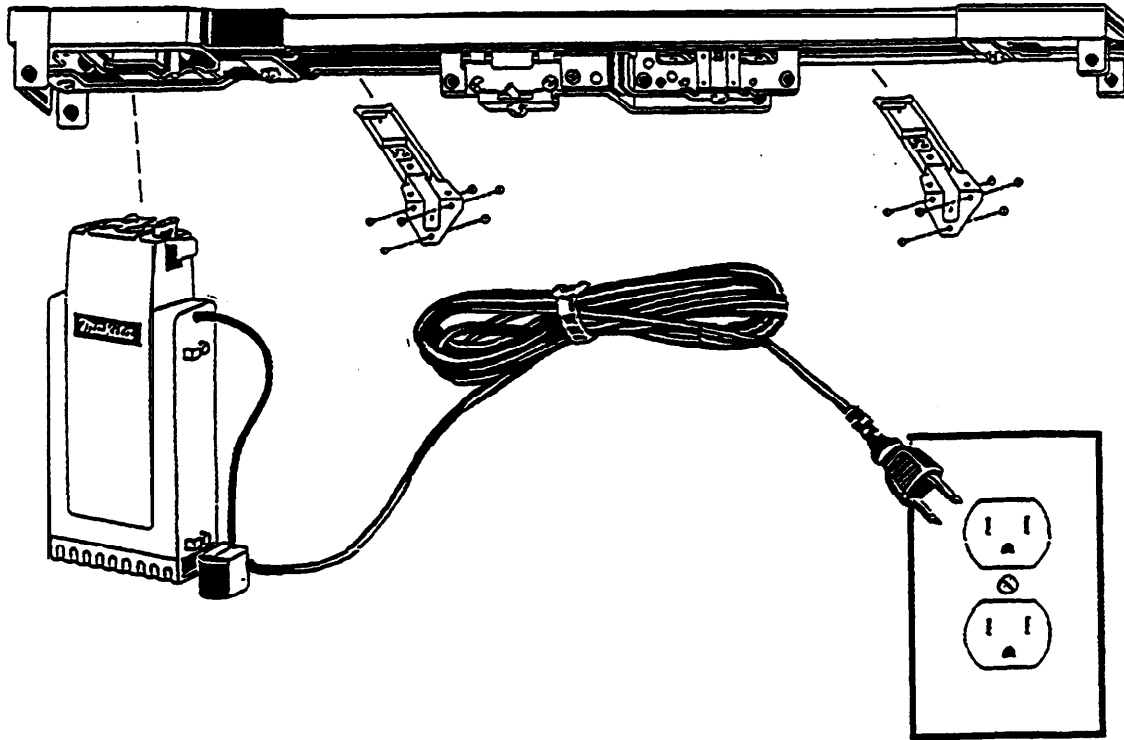

Figure 22

Part 5: Wiring and Application Diagrams and Product Spec Sheets



Assembly Diagram



110V
wall Receptacle

Simultaneous 2 Motor Operation Connection

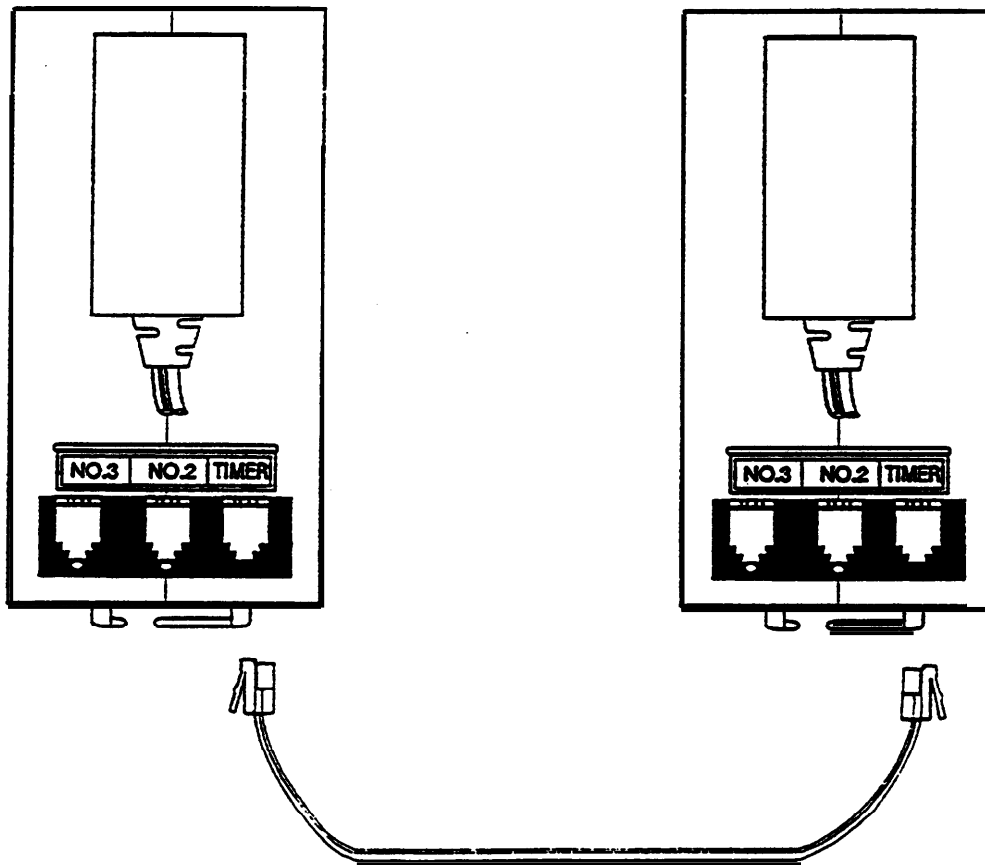

Simultaneous operation of two "Parent" motors can be achieved by connecting them from "Timer" port to "Timer" port using connecting wire ZZ22CW-2 or ZZ42CW-2. Both of these connecting wires have only two of the four wires connected; data and ground. Both motors work simultaneously regardless of which IR receiving eye the remote is pointed toward.

Application Sheet

"Daisy-Chain" - Multiple motors operating simultaneously

AS shown: Three motors linked together operated by one wall switch.
Up to ten (10) motors can be wired in sequence

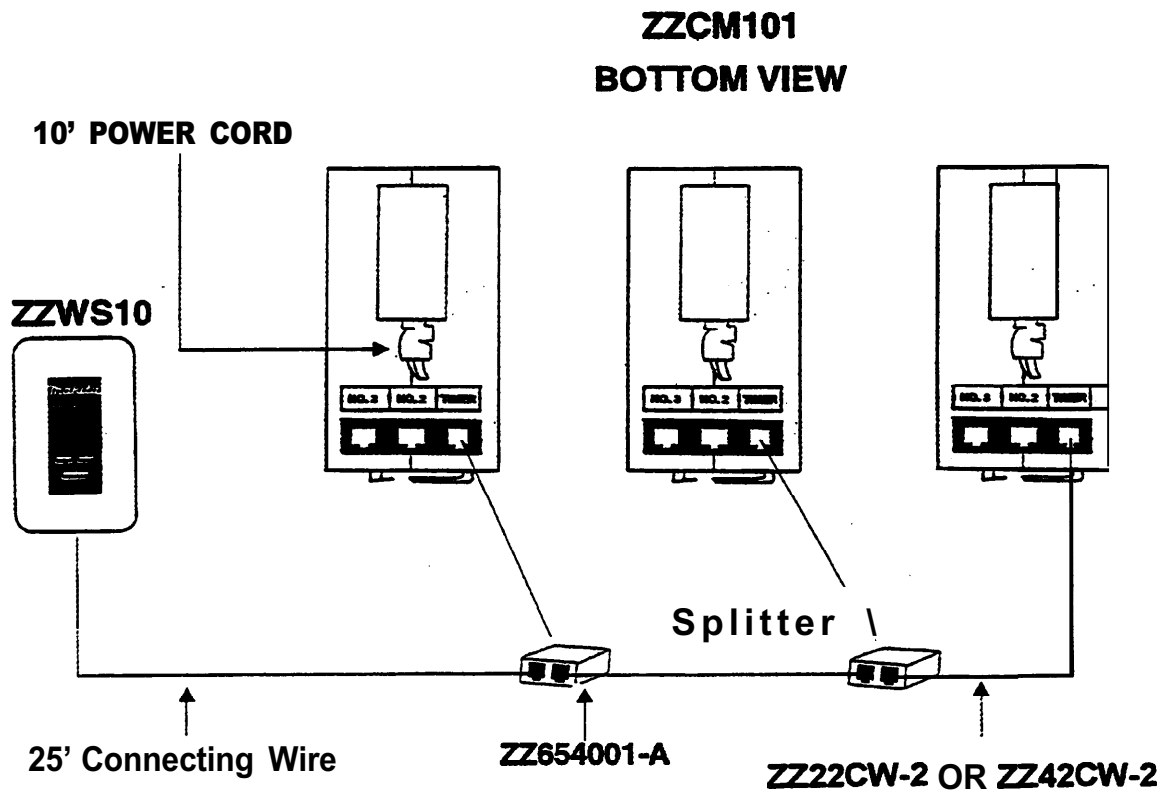

Necessary Components: (1) ZZWS10, (2) ZZ654001-A (Splitter), (3) ZZCM101,
(2) ZZ22CW-2 or ZZ42CW-2

Recommended Components: 22782001 -A Modular Crimping Tool w/ (10) Male Modular
Plugs for customizing 22' & 42' connecting wire lengths

Application Sheet

Maximum Doubles using RC60

with simultaneous over-drapery independent from simultaneous under-drapery

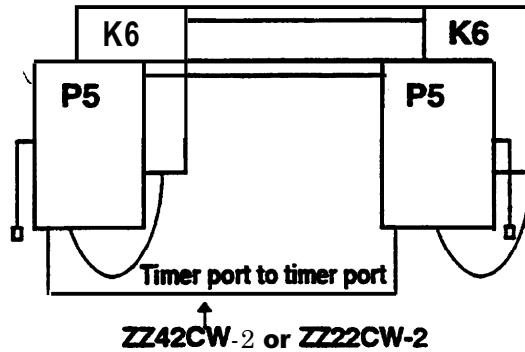
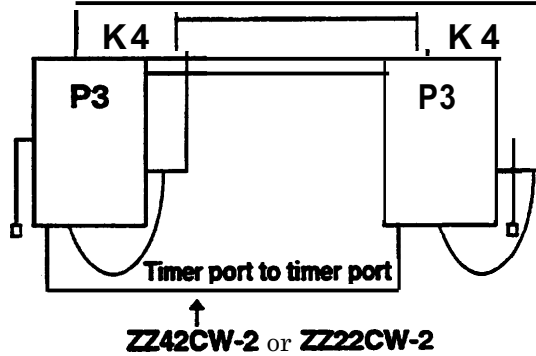
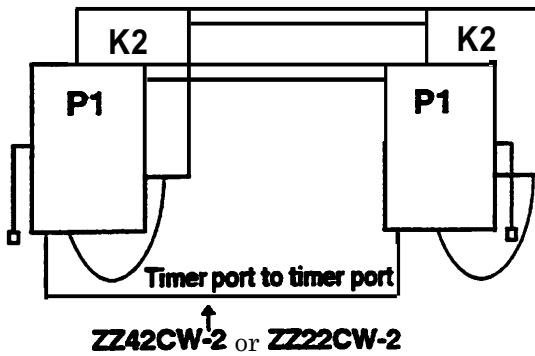

Necessary Components: (8) ZZCM101, Change of address needed on 4 motors; two @ #3 and two @ #5, (8) ZZCM301 and (4) ZZ42CW-2 or ZZ22CW-2

Recommended Components: 22782001-A Modular Crimping Tool w/ (10) Male Modular Plugs for customizing 22' & 42' connecting wire lengths

Optional Components: Splitter - allows use of wall switches or timers

Motor Specifications

Model ZZCM101

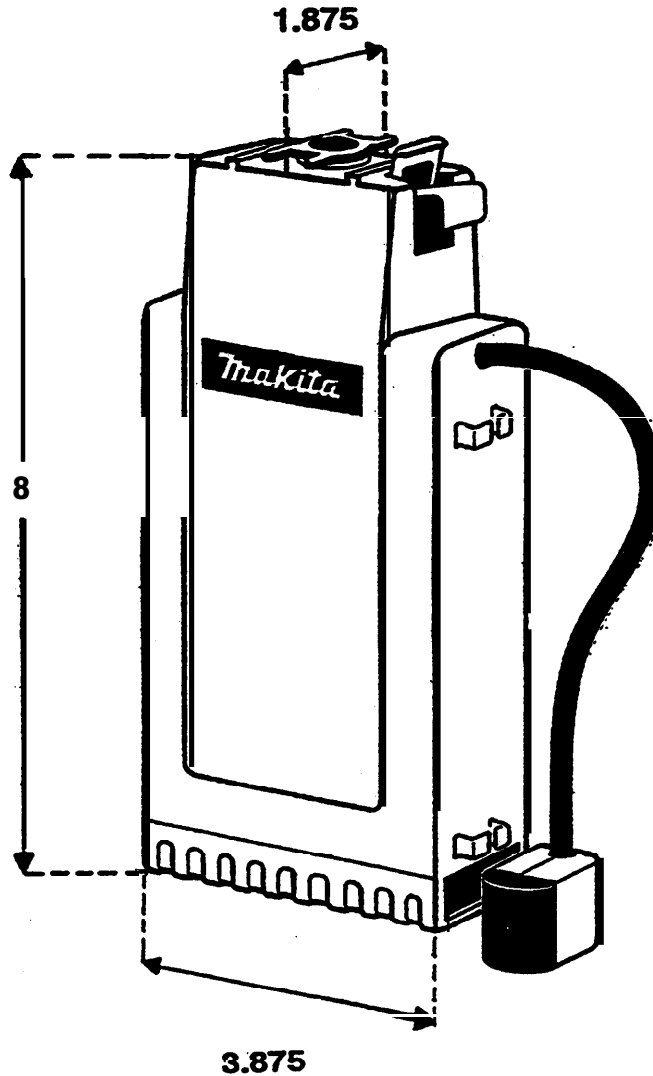

(H)x(W)x(D)	8" x 3-7/8" x 1-7/8"	Remote Range	35 FT.
Weight	2.3 LBS.	Max. Drape Weight	60 LBS.
Voltage	120 VAC	Power Cord Length	10 FT.
Amperage	.31 Amp.	Power Cord Type	SPT-2 18/2 AWG
Cycle	60 HZ	Voltage Surge Suppressor	Yes
U.L. Listed	Yes	Thermal Overload Protector	Yes

Motor Specifications

Model ZZCM301

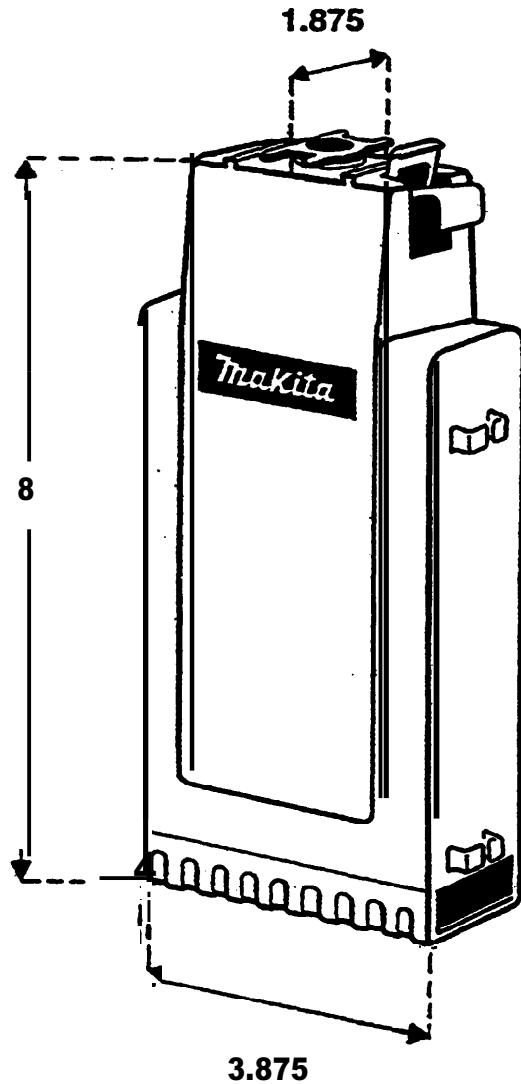

(H)x(W)x(D)	8" x 3-7/8" x 1-7/8"	Remote Range	35 FT.
Weight	2.3 LBS.	Max. Drape Weight	60 LBS.
Voltage	120 VAC	Power Cord Length	10 FT.
Amperage	.31 Amp.	Power Cord Type	SPT-2 18/2 AWG
Cycle	60 HZ	Voltage Surge Suppressor	Yes
U.L. Listed	Yes	Thermal Overload Protector	Yes

Splitter Specifications

Model 22654001-A

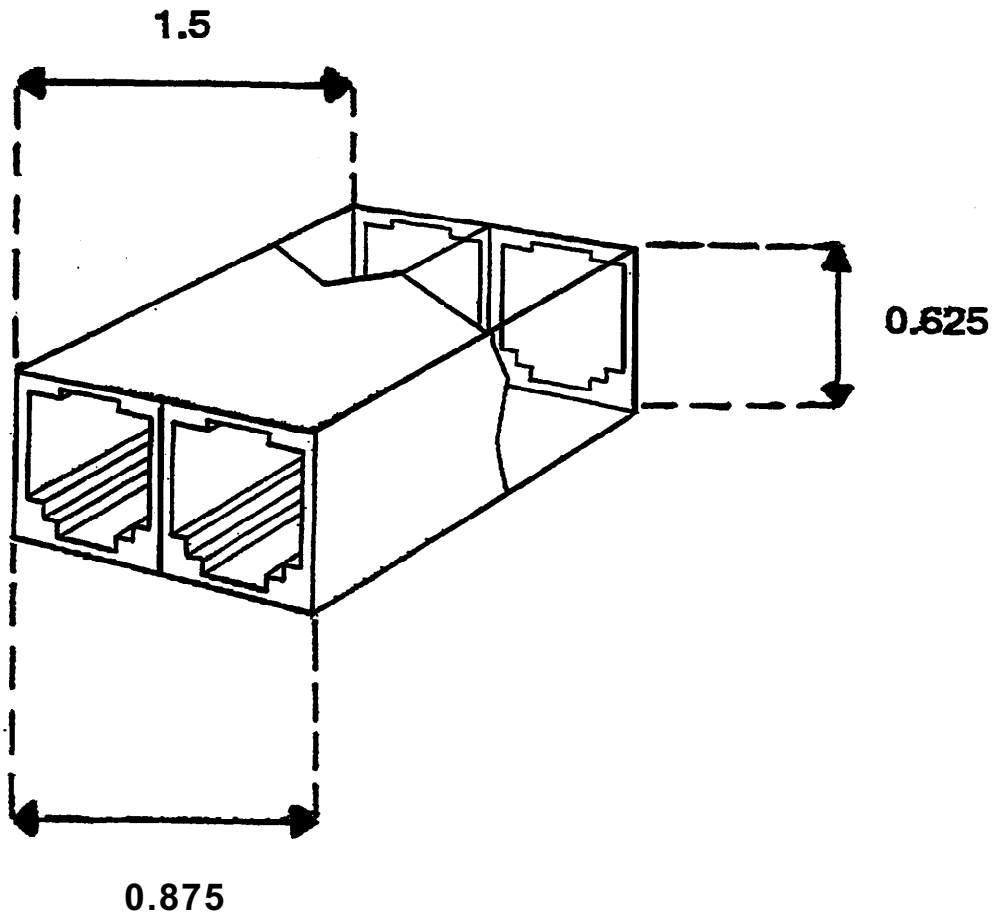

(H)x(W)x(D)	5/8" x 7/8" x 1 -1/2"	For use with multiple controls e.g.
Connecting Cord	6 Inches	Timer, Wall Switch, Extended I.R.
Voltage	Low / +5 volts	Receiver or "Chaining Motors".
Wiring Type	Class 2	

Contact Closure Interface

Model 22631103-A

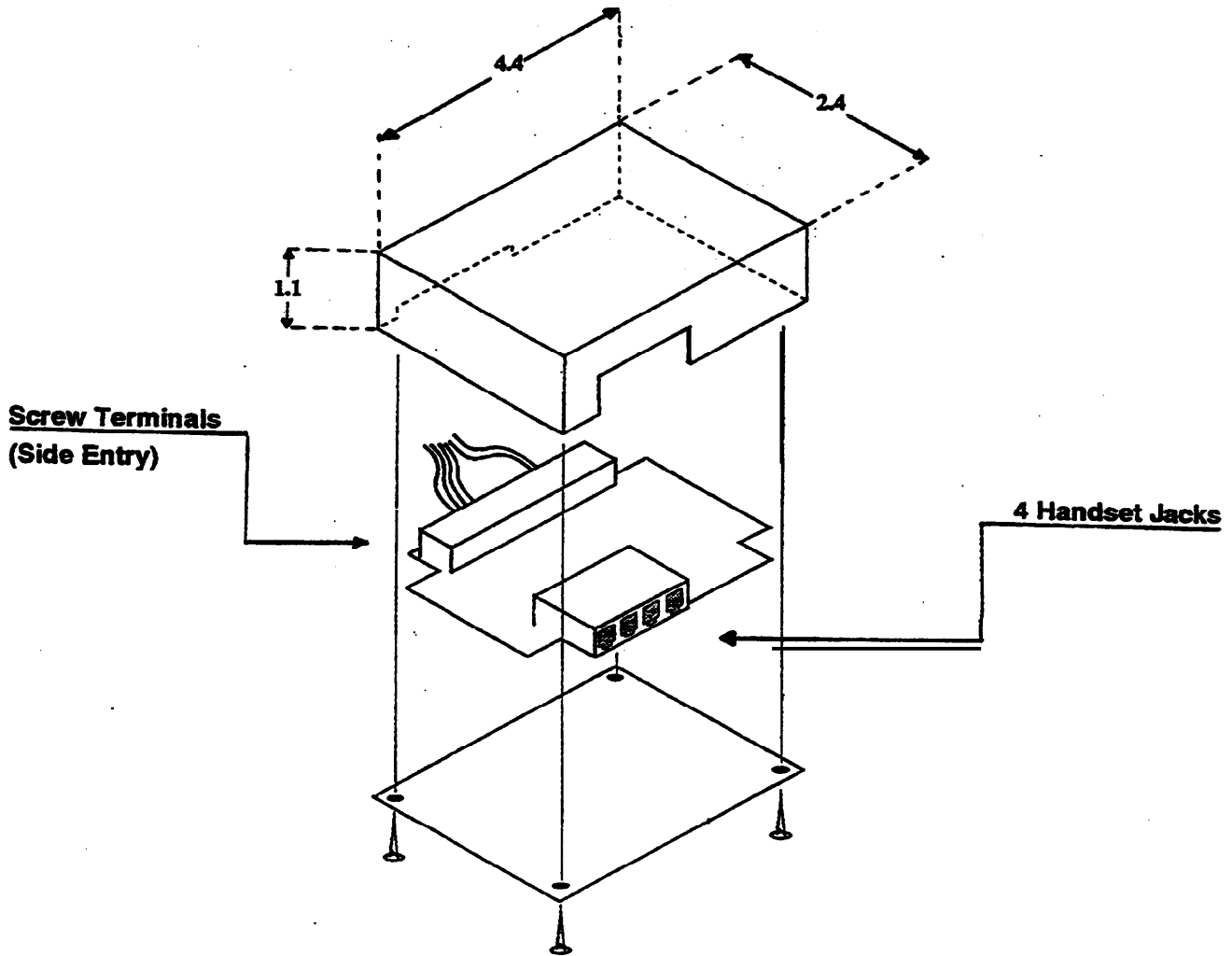

(H)x(W)x(D)	4-13/32" x 2-13/32" x 1-3/32"
Voltage	Low / +5 volts
Out-Put Wiring	Class 2 - Flat 4 wire (phone type) 26 AWG
In-Put Wiring	Gage not exceed 18 AWG
ABS Case Flame Rating	94V-0

Connecting Wire Specifications

Part Number **ZZ22CW, ZZ42CW**

26 AWG (7x34) Stranded Bare Copper Conductors - 4 Conductor Wire

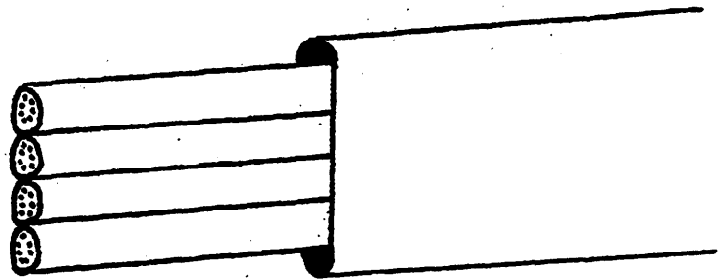
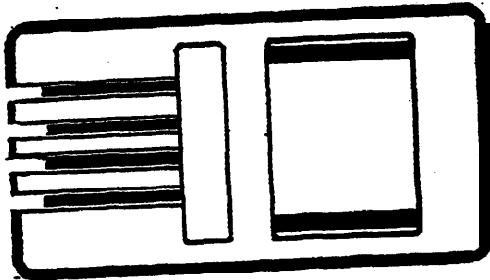

Outside Diameter	2.3mm x 4.9mm/.090" x .193"
Jacket Thickness	.55mm/.02"
<i>Insulation Construction</i>	
Avg. Thickness	24 (+/-) 0.05
Min. Thickness	.13
<i>Physical Properties</i>	
Cold Bend Test	No Crack at 10 Degrees C/H
Flame Test	Self Extinguish 60S
Flexible Bend Test	No Fracture 100 Degrees C 168H
<i>Conductor Construction</i>	
Diameter of Wire	.158
Number of Wires	7
Lay Length of Strand	20
<i>Electrical Properties</i>	
Resistance of Conductor	0.1367 Ohms/M @ 20 Degrees C
Resistance of Insulation	1000M Ohms/KM @ 20 Degrees C
Dielectric Test	500V/1 MIN. AC
Spark Test	2Kv

Connecting Wire Specifications

Part Number ZZ22CW-2, ZZ42CW-2

26 AWG (7x34) Stranded Bare Copper Conductors - 4 Conductor Wire

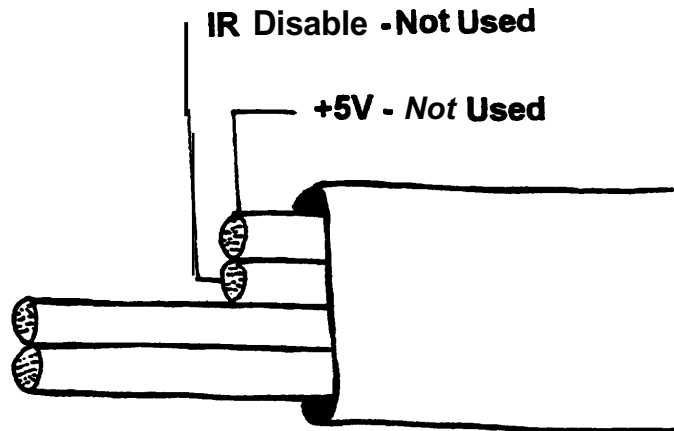
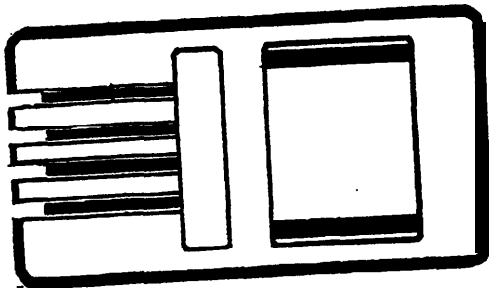

Outside Diameter	2.3mm x 4.9mm/.090" x .193"
Jacket Thickness	.55mm/.02"
Insulation Construction	
Avg. Thickness	24 (+/-) 0.05
Min. Thickness	.13
Physical Properties	
Cold Bend Test	No Crack at 10 Degrees C/H
Flame Test	Self Extinguish 60S
Flexible Bend Test	No Fracture 100 Degrees C 168H
Conductor Construction	
Diameter of Wire	.158
Number of Wires	7
Lay Length of Strand	20
Electrical Properties	
Resistance of Conductor	0.1367 Ohms/M @ 20 Degrees C
Resistance of Insulation	1000M Ohms/KM @ 20 Degrees C
Dielectric Test	500V/1 MIN. AC
Spark Test	2KV

Wall Switch Specifications

Model ZZWS10, ZZWS20, ZZWS30

WALL SWITCH OPERATION

Models: ZZWS10 single, ZZWS20 double,
ZZWS30 triple.

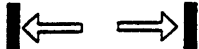

Denotes button to open drapery



Denotes button to close drapery

STOP

Denotes button to stop in any position



Model ZZWS10
for one motor



Model ZZWS20
for two motor



Model ZZWS30
for three motors

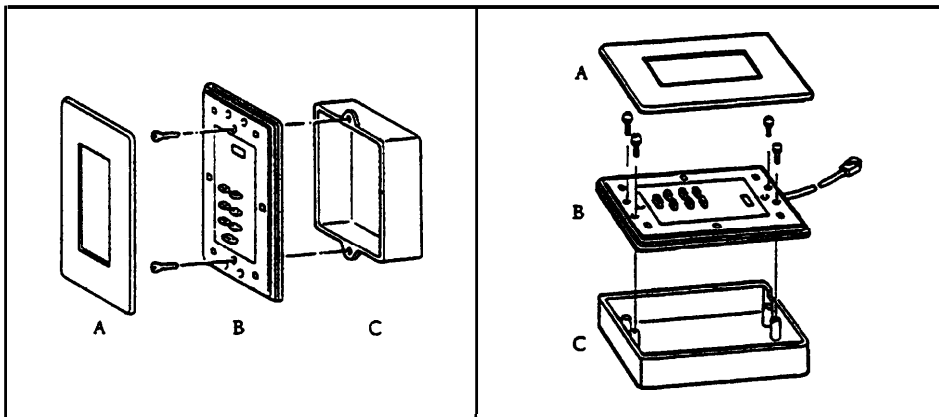
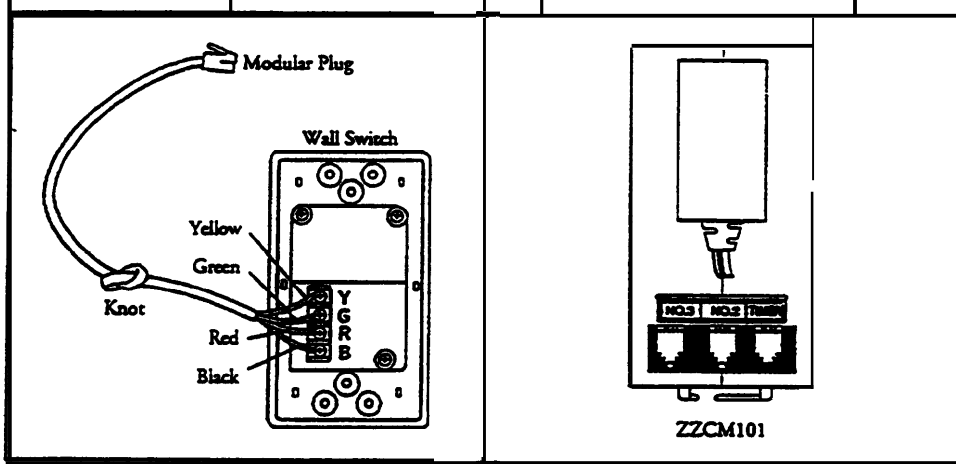

Comes with 25', 26 AWG flat phone wire with spade lugs for attachment to wall switch and male modular plug that connects to the "Timer Port" of ZZCM101 motor.

Timer/Input Port

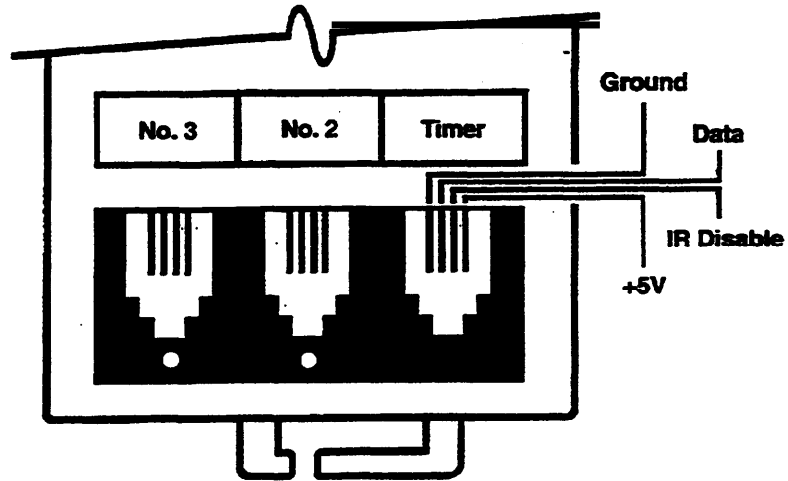

Labeled timer port, better described as the *Input Port* for controls.

Used for the timer, wall switch, contact closure interface and multiple parent motor connections.

Track Specifications

Model ZZ09TK, ZZ09TK-WH, ZZ20TK, ZZ20TK-WH

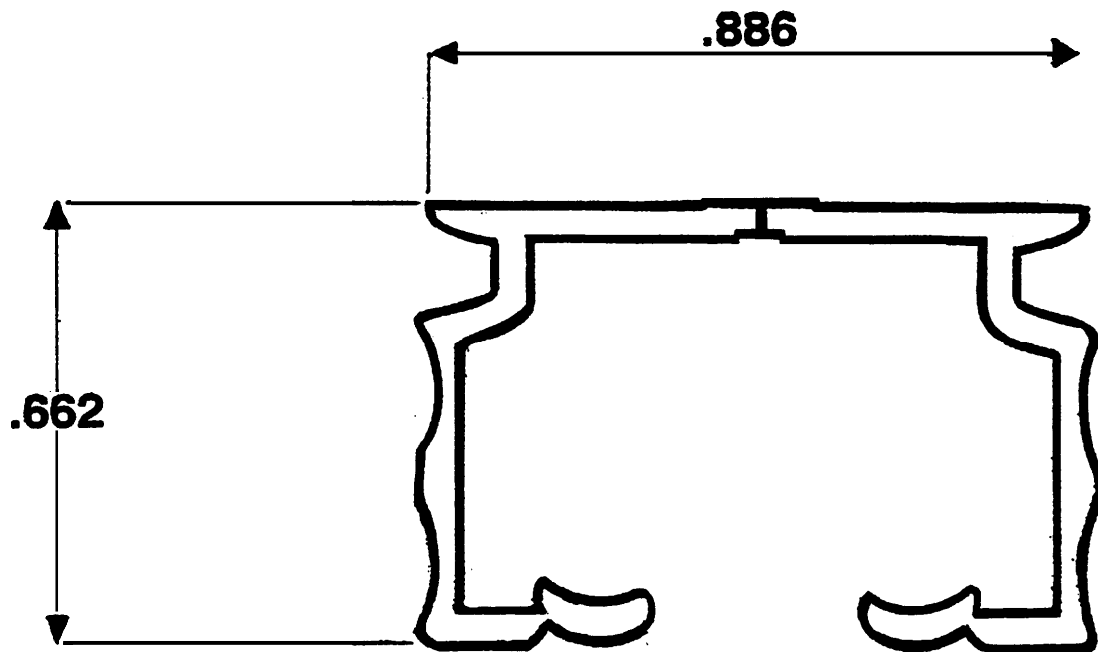

Material	6063-T5
Neight per Foot	2.3 Lbs.

Finish	Powder Coat White or Clear Anodized
Typ Wall	.050

Bracket Specifications

Models **ZZ3SWCB, ZZ3SWCB-WH, ZZ6DWCB, ZZ6DWCB-WH**

Universal for Wall or Ceiling Mounting

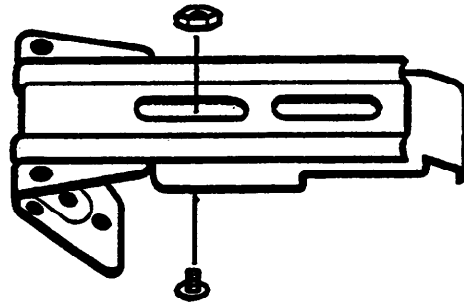

ZZ3SWCB & ZZ3SWCB-WH

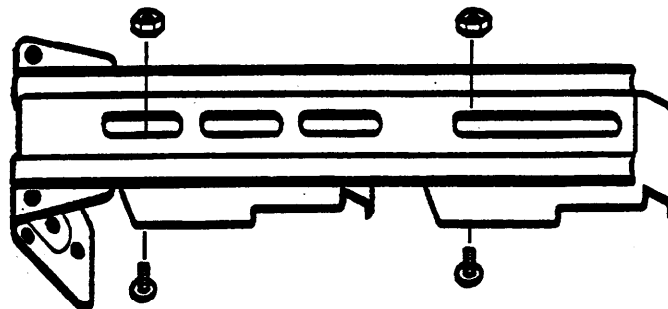

ZZ6DWCB & ZZ6DWCB-WH

ZZ3SWCB (Zinc) & ZZ3SWCB-WH (White) for Single Tracks. Adjustable wall projection from 2-3/8" to 4-1/8".

ZZ6DWCB (Zinc) & ZZ6DWCB-WH (White) for Double Tracks. Adjustable wall projections (inside track) 2-1/2" to 4-1/8", (outside track) 5-3/8" to 7-3/8"