

# SmartPath™

## IRC-2.0 & IRC-2.1 Surface Mount Mini Infrared Receivers

### INSTALLATION INSTRUCTIONS

The IRC-2.0 and IRC-2.1 are very small IR Receivers designed to be mounted on flat surfaces in furniture recesses, under shelves, etc., using the double-sided tape supplied. Among their unique features is an exclusive Ambient Noise Suppression (ANS) system. It acts to push down IRI, CFL, EMI, or ESI noise sources so that stronger signals from IR remotes have adequate margin for command of the controlled component.

**Note:** The ANS will take a few seconds to adjust to a given noise source. During this time, the blue Activity LED will glow brightly and then fade out. If the interference disappears momentarily, then returns, the fade down process will repeat. Certain noise sources, however, (such as Plasma Screens) may result in low-level flickering even after the fade down. This is normal. Such signals have been acted upon by the ANS, allowing most equipment to be controlled.

Fig. 1

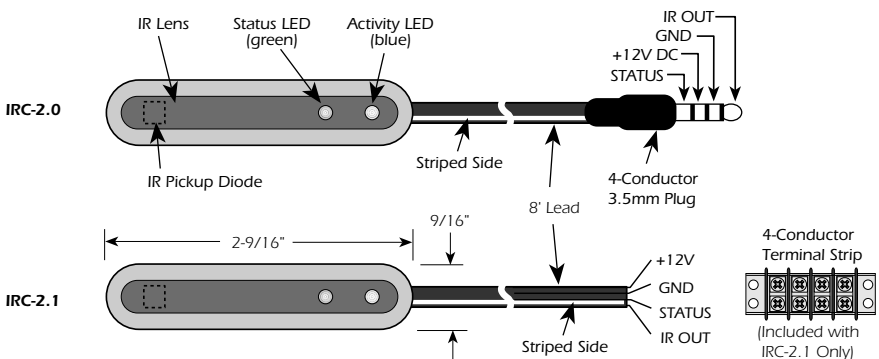

### FEATURES/SPECIFICATIONS

- The IRC-2.0 and IRC-2.1 are identical except for lead termination. (See Fig. 1) The IRC-2.0 has a unique 3.5mm quad plug to accommodate STATUS as well as IR, Power and Gnd connections. The IRC-2.1 comes with stripped ends plus a 4-conductor terminal strip allowing interface connections to in-wall room-to-room wiring.
- Exclusive Ambient Noise Suppressor (ANS) system.
- STATUS Indicator: Green LED for System On/Off indication.
- ACTIVITY Indicator: Blue LED indicates IR signal activity in a completed circuit with a Terminator or an Emitter.

- Requires Power Supply, Terminator Block and Emitters for IR Repeater operation.
- Mounting: Attaches to any flat surface using the included double-sided tape. The tape may be applied to the back, top, or bottom surfaces of the IRC-2.0 / IRC-2.1 to accommodate the installation.
- Power: 12V DC @ 6 mA. Supplied from connected Terminator.
- IR Lens rejects visible light interference.
- Crosshatch Shield (internal) inhibits EMI/ESI Interference.
- Carrier Frequency Acceptance Range: 28 to 90 kHz.
- Control Range: Up to 35 feet, depending on remote strength and ambient noise conditions.
- Control Angle:  $\pm 50^\circ$  off axis.
- Room-to-Room Wire Recommendations: Use 4-conductor (min.) 24 gauge unshielded solid or stranded copper wire up to 1200' (Cat. 5e ok), 22 gauge up to 2000', 20 gauge up to 3000' and 18 gauge up to 5300'.
- Maximum recommended cable length: 5300' with 18 gauge.
- Dimensions: 2 7/8" (65mm) L x 3/8" (14mm) W x 1/2" (13mm) D.

## SYSTEM CONNECTIONS

The following are a few typical applications of the IRC-2.0 and IRC-2.1 for IR repeater systems.

### A Basic System

Fig. 2 shows a basic plug-and-play installation, such as controlling components that are behind closed cabinet doors or in a closet.

Fig. 2

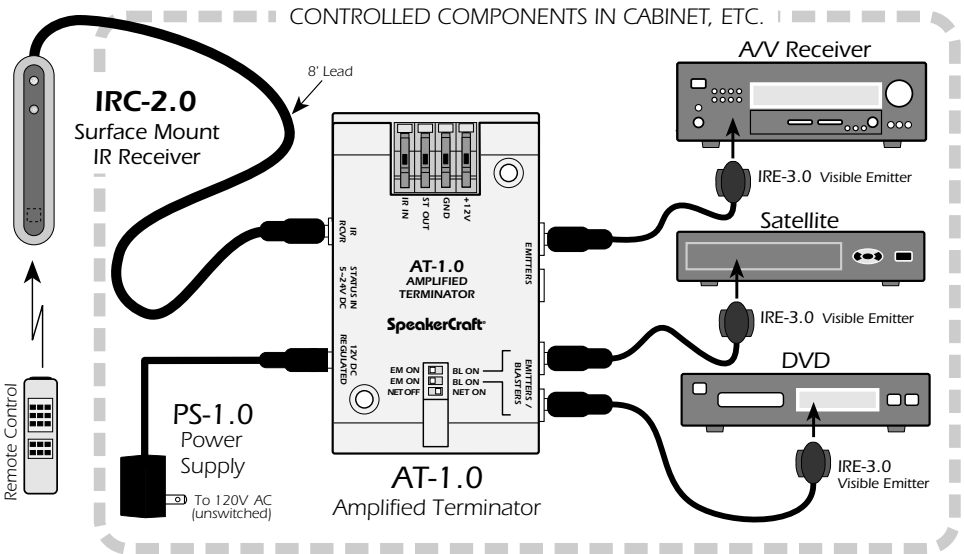

1. Mount the IRC-2.0 in a recessed cabinet area or under a shelf, using the two-sided adhesive tape supplied.
2. Plug the IR Receiver and Emitters into the SpeakerCraft AT-1.0 Amplified Terminator, as shown.
3. Set the DIP switches on the AT-1.0 to EM ON and NET ON or OFF.
4. Plug in the Power Supply.
5. The remote control, fired at the IRC-2.0, should now control the components.

## A Multi-Room System

Fig. 3 is an example of the IRC-2.1 wired IR Receiver in a multi-room system with other SpeakerCraft IR receivers in various rooms, plus a local IRC-2.0. These control the various components in the main room or equipment area.

Fig. 3

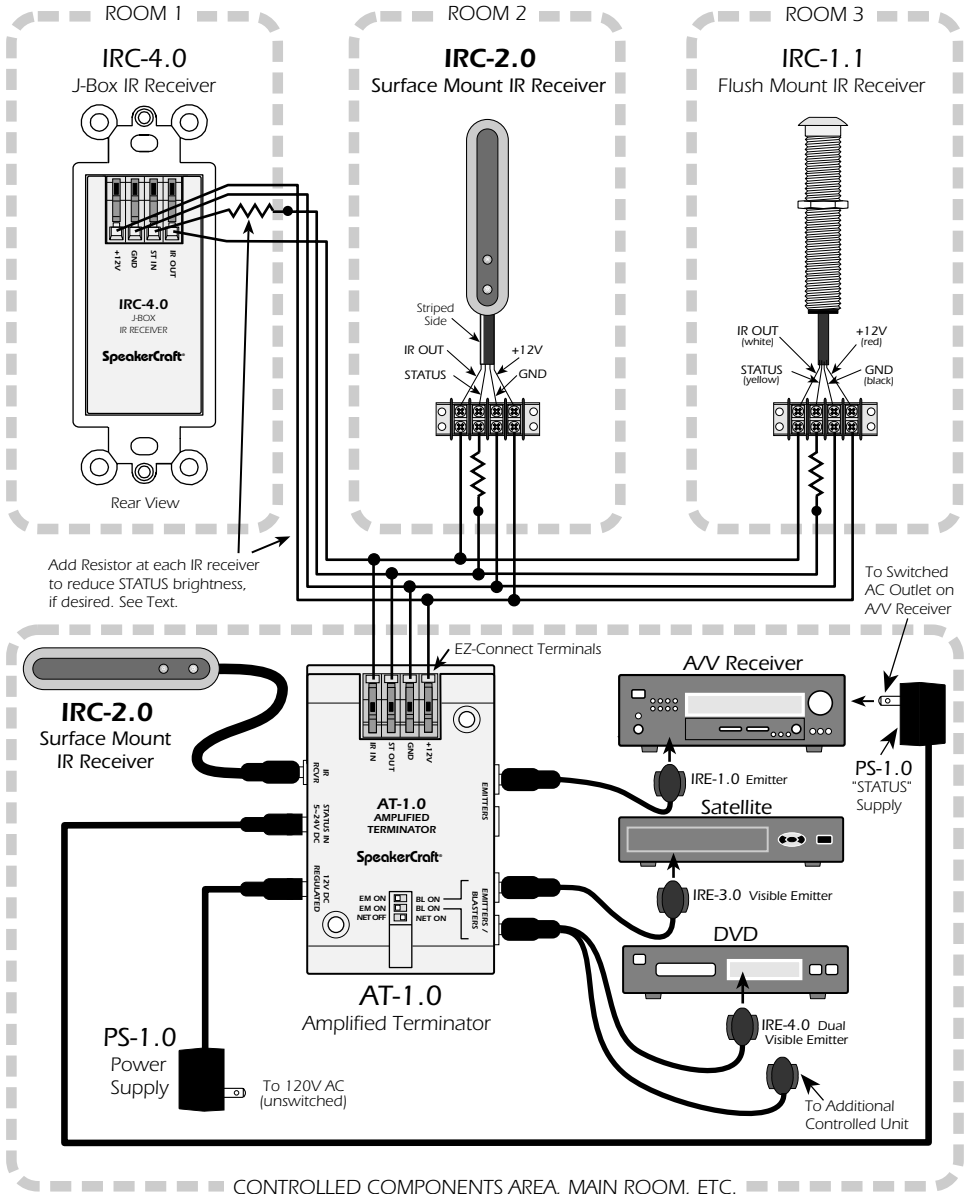

1. Pull 4-conductor wire from each room (home runs) to the AT-1.0 Terminator near the controlled components.  
**Note:** Use 24 gauge unshielded solid or stranded copper wire up to 1200' (Cat. 5e ok), 22 gauge up to 2000', 20 gauge up to 3000' and 18 gauge up to 5300'. Total lengths include all wire runs from each room added together, not just the longest single run. If using shielded wire, these lengths would be reduced by approximately 30%. Also, to achieve operation with long lengths, the lower DIP switch on the AT-1.0 **must** be set to the NET ON position.
2. Connect IR receivers in each room to the 4-conductor home runs as shown, using the 4-conductor terminal strip supplied.
3. Connect the home run wires to the correct terminals on the AT-1.0 EZ-Connect Terminals.  
**Note:** You may use the SpeakerCraft CB Connecting Block (not illustrated, stock # ASM20200) to help connect the many paralleled home run wires to the AT-1.0 EZ-Connect Terminals.
4. Install and plug the various emitters into the AT-1.0.
5. Set the DIP switches to EM ON (or BL ON if using Blasters behind closet doors) and NET ON.
6. Plug the local IRC-2.0 IR Receiver into the IR RCVR jack.
7. Plug in the PS-1.0 12V DC Power Supply.
8. A remote control, fired at the IR receivers, should now control the components.

**Note:** Refer to the SpeakerCraft AT-1.0 Instructions for Power Supply considerations.

### **STATUS Brightness**

Fig. 3 also shows how an external resistor can be added to reduce the brightness of the Status LEDs on SpeakerCraft IR Receivers to any desired level.

In this example, a PS-1.0 12V DC Power Supply is used as the voltage source to indicate ON/OFF status of an A/V Receiver.

Choose a resistor value that achieves the brightness you desire (about 2.2k to 12k, 1/8 W). Connect it in series with the STATUS lead on each IR receiver desired, as shown.

### **LIMITED 5-YEAR WARRANTY**

SpeakerCraft warrants this product to be free of defects in materials or workmanship. This extends for five years from the date of purchase by the original consumer. Any products returned to SpeakerCraft and found to be defective by SpeakerCraft within the warranty period will be repaired or replaced, at SpeakerCraft's option, at no charge. SpeakerCraft will not be responsible for the actual cost of installation or removal of the product, nor for any incidental or consequential damages. Some states do not allow the exclusion or limitation of incidental or consequential damages, so the above limitation may not apply to you. This warranty gives you specific legal rights. You may have additional legal rights that vary from state to state.

**SpeakerCraft®**

SpeakerCraft • 940 Columbia Ave., Riverside, CA 92507 • 800-448-0976 • Fax 888-599-9059  
www.speakercraft.com

LIT01200