



Model: TPR-120 Three-Phase Repeater

Installation Guide and Owner's Manual



3. Run wires from a three-pole circuit breaker to the workbox for Phase A, Phase B, Phase C, and Neutral (see illustration below).
4. Use wire nuts to connect the TPR's black wire to Phase A, and the red wire to Phase B, and the blue wire to Phase C. Connect the TPR's white wire to Neutral. Check that there are no bare wires protruding and cover the wire nuts with insulating tape if necessary.
5. Check all wiring and connections, and turn on the main breaker.
6. All three status LEDs will light up if all of the connections are proper.

FUNCTION

The TPR-120 Three-Phase Repeater is a small electronic device that enables communication between PulseWorx™ & other devices using the Universal Powerline Bus (UPB™) method of communication on a three-phase 120/208VAC 60Hz powerline. The main purpose of the TPR is to transfer UPB™ multi-packet messages transmitted on one phase (leg) of the electrical system and strongly repeating them on to the other phases (legs) to ensure proper communication.

Why Do I Need a TPR-120?

UPB™ communication was designed to work on a single phase powerline. However in a three-phase environment the signals will not directly jump across all three phases of a 208V electrical system. The TPR was invented to take any UPB™ multi-packet generated signal on a single phase and repeat them onto all three phases of the powerline.

INSTALLATION

The TPR-120 works best when installs as close to the main circuit breaker panel as possible.

Note: Installation must be carried out by a qualified electrician only. The main breaker must be turned off during installation and the repeater must be installed in a suitable junction box or equivalent enclosure. Installation must be carried out in accordance with all applicable codes and requirements, including, but not limited to, the National Electrical Code (NEC).

1. Turn off the power at the main breaker panel.
2. Install the repeater into a suitable workbox or equivalent enclosure.

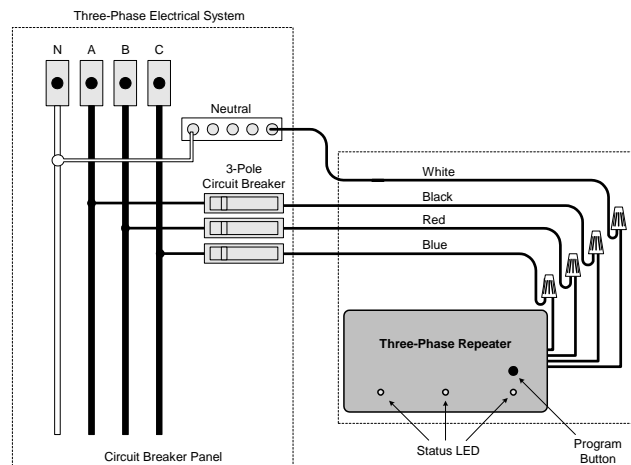

CONFIGURATION

Although the TPR-120 will operate without any configuration, we *highly* recommend that you use the UPStart Setup Software to add your TPR to the UPB network with a UnitID. Once added to the network UPStart can then be used to adjust the TPR's receive sensitivity and perform communication tests between other devices to insure proper system signal strength.

Adding the TPR-120 to the UPStart Network

The TPR-120 is added in to a network just like most other UPB™ devices. Select Device→Add Device, place the TPR into Setup Mode, and click the Next button. The TPR's Program Button is tapped 5 times to enter the TPR into Setup Mode and double-tapped to exit from Setup Mode. While in Setup



19201 Parthenia St. Suite J
Northridge, CA 91324
P: 818.701.9831 F: 818.701.1506
pwxsales@pcslighting.com
www.pcslighting.com



Model: TPR-120 Three-Phase Repeater

Installation Guide and Owner's Manual

Mode the Status LEDs will blink blue. Once the TPR is added to the network, it may be assigned a Room and Device Name that are meaningful for identification purposes.

Performing Communication Tests

It is important that the communication of your UPB™ network be tested to insure proper system signal strength. UPStart has a Repeater Communication Test that will test how well each device communicates to the TPR and how well the TPR communicates to all devices. The Repeater Communication Test will show a record of the signal strength, noise level, and phase at all devices.

Adjusting the Receive Sensitivity

If powerline noise is severe it may sometimes cause UPB™ communication to become unreliable. All PulseWorx devices, including the TPR, have an adjusted receive sensitivity which may be set to LOW via UPStart. This will help block the noise from affecting the reception.

The TPR additionally has a manual programmable (push-button) method to adjust its receive sensitivity. Press and hold the Program Button for 5 seconds and then release it. The Status LEDs will blink red to indicate the current receive sensitivity setting – once for LOW or twice for HIGH. To adjust the receive sensitivity to LOW single-tap the Program Button. To adjust the receive sensitivity to HIGH double-tap the Program Button. Press and hold the Program Button for 5 seconds to set the new receive sensitivity. Release the Program Button and the Status LEDs will turn back to blue.

Once the Receive Sensitivity has been changed the Repeater Communication Test should be repeated to insure to insure proper system signal strength and communication.

OTHER THINGS YOU SHOULD KNOW

Multi-Packets

The Three-Phase Repeater is designed to automatically repeat all multi-packet messaging transmissions, which it receives in order to enable UPB™ communication on an entire three-phase network. A multi-packet transmits the

same basic information more than once back-to-back. All PulseWorx™ devices (and most other UPB™ devices) are pre-configured at the factory to use 2-time multi-packet messaging. If any of your devices are configured to use uni-packet transmissions then the TPR will not repeat them.

UPStart and the TPR

UPStart normally uses uni-packet transmissions to communicate to UPB™ devices however, once the TPR is added to the network, it will automatically switch to using multi-packet transmissions. UPStart indicates that it has switched to two-time multi-packets by displaying TX=2 in the status bar. Next to this indication UPStart will also display which phase (A, B, or C) the PIM is plugged into.

UPStart has a Network Discovery function that can quickly discover which Unit IDs are in use. In a three-phase electrical environment UPStart must use the TPR to gain access to this information for all three-phases.

Status LED Indications

The TPR has a blue/red status LED for each phase of the powerline. When the TPR is transmitting on the powerline it will turn the LED red. When it is receiving on the powerline it will turn the LED purple. When nothing is happening on the powerline the LED will stay blue.

Multiple TPR-120s

We do not recommend installing more than one Three-Phase Repeater on a single electrical system.

LIMITED WARRANTY

Seller warrants this product, if used in accordance with all applicable instructions, to be free from original defects in materials and workmanship for a period of five years from the date of purchase. Refer to the warranty information of the PulseWorx website (www.PulseWorx.com) for exact details.



19201 Parthenia St. Suite J
Northridge, CA 91324
P: 818.701.9831 F: 818.701.1506
pwxsales@pcslighting.com
www.pcslighting.com