

## CHANNEL VISION Limited Warranty

Channel Vision Technology will repair or replace any defect in material or workmanship which occurs during normal use of this product with new or rebuilt parts, free of charge in the USA, for two years from the date of original purchase. This is a no hassle warranty with no mail in warranty card needed. This warranty does not cover damages in shipment, failures caused by other products not supplied by Channel Vision Technology, or failures due to accident, misuse, abuse, or alteration of the equipment. This warranty is extended only to the original purchaser, and a purchase receipt, invoice, or other proof of original purchase date will be required before warranty repairs are provided.

Mail in service can be obtained during the warranty period by calling (800) 840-0288 toll free. A Return Authorization number must be obtained in advance and can be marked on the outside of the shipping carton.

This warranty gives you specific legal rights and you may have other rights (which vary from state to state). If a problem with this product develops during or after the warranty period, please contact Channel Vision Technology, your dealer or any factory-authorized service center.

500-101 rev A

# CHANNEL VISION™

## P-0925 Paging Module

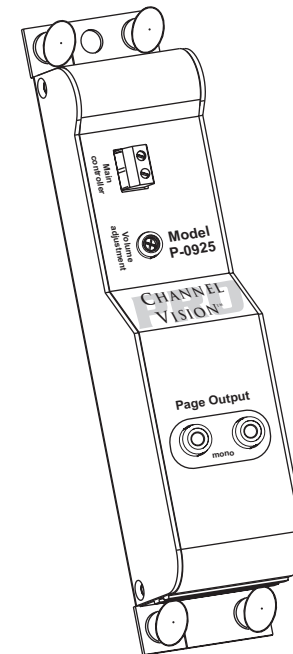

CHANNEL VISION™

234 Fischer Avenue · Costa Mesa, CA 92626  
(714) 424-6500 · (800) 840-0288 · (714) 424-6510 fax  
www.channelvision.com · email: sales @ channelvision.com

The **P-0925** allows Channel Vision's C-0920 or TE110 to provide an audio output that may be connected to the paging input of a whole house amplifier. The new Channel Vision's **PRO** form factor allows the P-0925 to be mounted in a structured wiring enclosure, a 19" rack\*, or screwed to any flat surface.

- Enables paging from a C-0920 or TE110
- Simple connections
- Quick and easy installation

Volume level adjustment allows the paging signal to be increased or decreased to match the input requirements of the paging amplifier.

Screw terminals allow easy connection to the C-0920 or TE110. This simple 2-wire connection is not polarity sensitive.

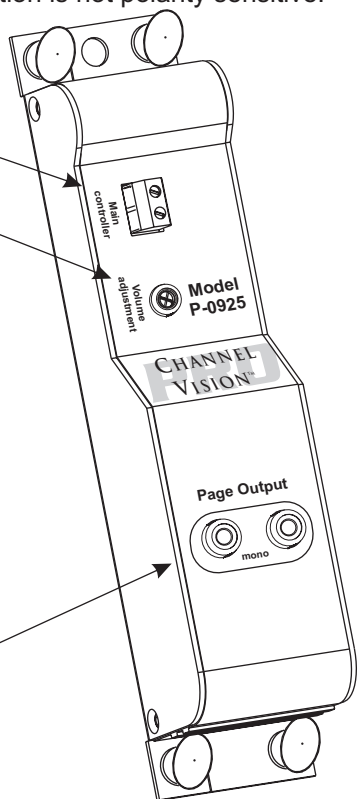

Paging output sends audio to the paging input of whole-house audio amplifier.  
 Note: be sure to use an amplifier that has an audio-sensing page input. Such as the P-1014.

Product Dimensions: 1.5"W x 6.5"H x 1.25"D

## Mounting Options

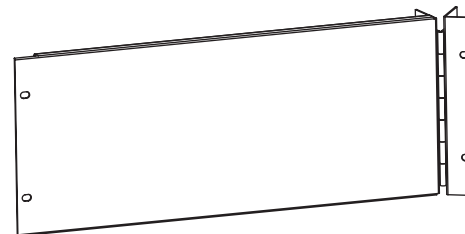

The **NEW P-1300** from Channel Vision's Pro-series product line is the perfect home for the P-0925. The P-1300 is a hinged plate designed to fit into a standard 19" rack.

The **P-1300** hinges open to maintain a clean look and provide easy access for servicing equipment.

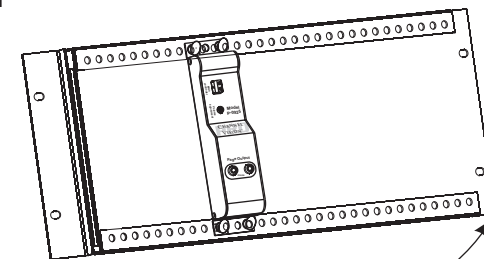

The P-1014 can also be mounted in a standard structured wiring enclosure or screwed to a wall or flat surface as shown below.

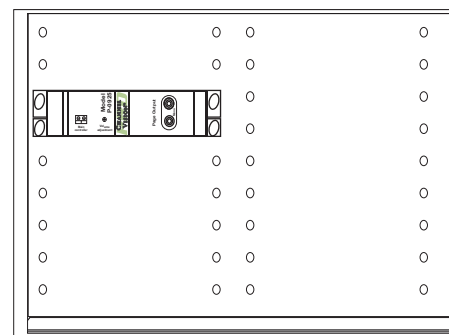

Cut or remove the nylon snap pin.

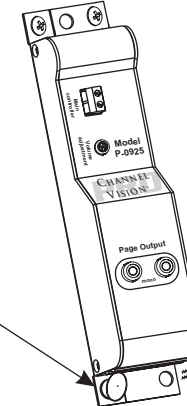

Install screws in empty holes.

# Operating Instructions

## Whole House Paging with the P-1014

Channel Vision's P-1014 A-BUS™ distribution module provides an integrated audio sensing local input that can be used as a paging input. Simply make the connections shown below and place the signal priority switch in the local position.

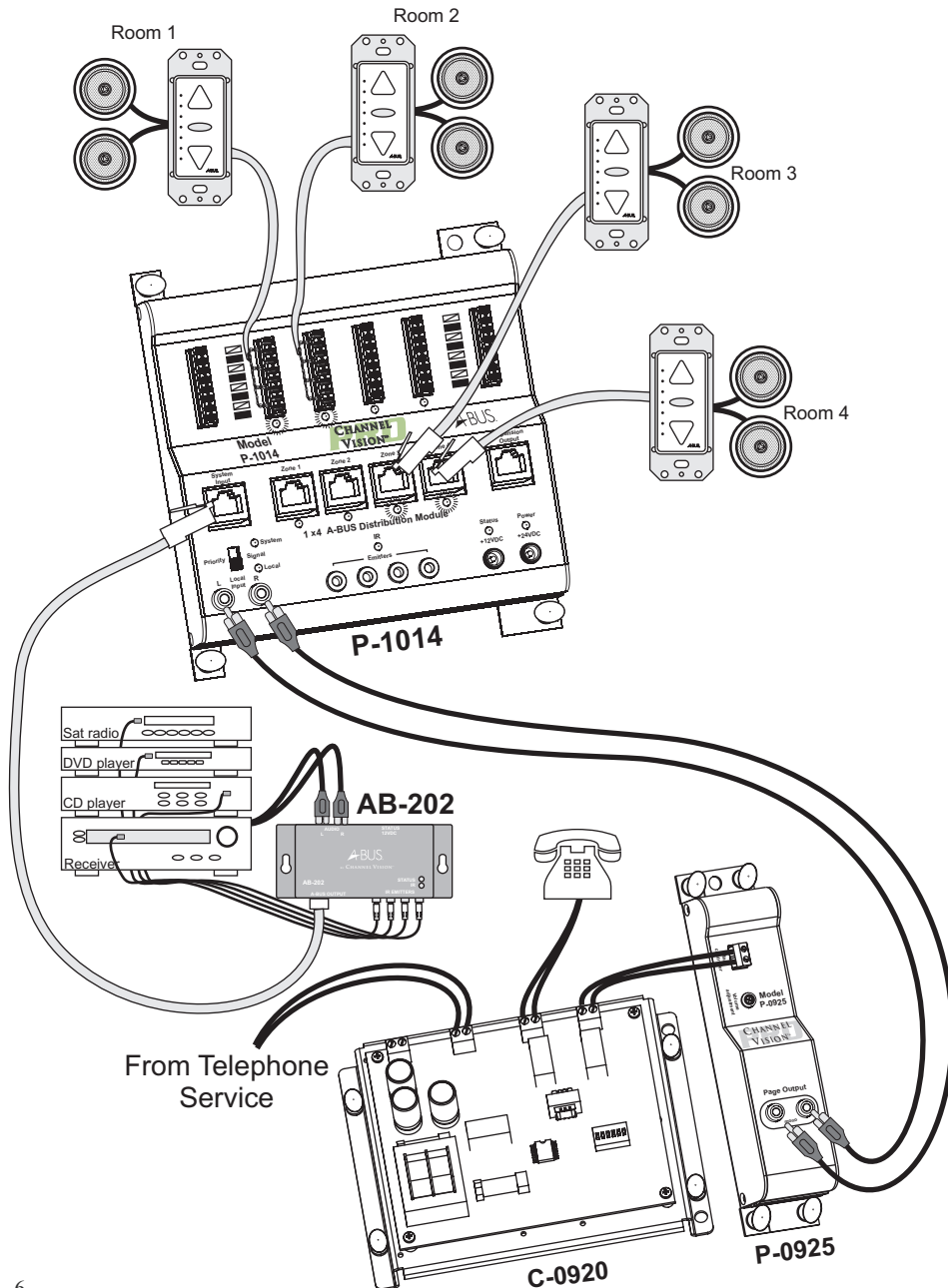

To make a page:

1. Pick up the telephone.
2. Press the activation key 3 times.  
Note: the activation key may be either \* or #.  
This setting is determined by the TE110 or C-0920.
3. Make your announcement.
4. Hang up the telephone.

Example: (assume # is the activation key)

1. Pick up the telephone



2. Press pound 3 times



Note: the 3rd press may produce an audible tone in the speakers, this is normal.

3. Make the announcement



4. Hang up the telephone



## Paging Only

Make all connections before applying power.

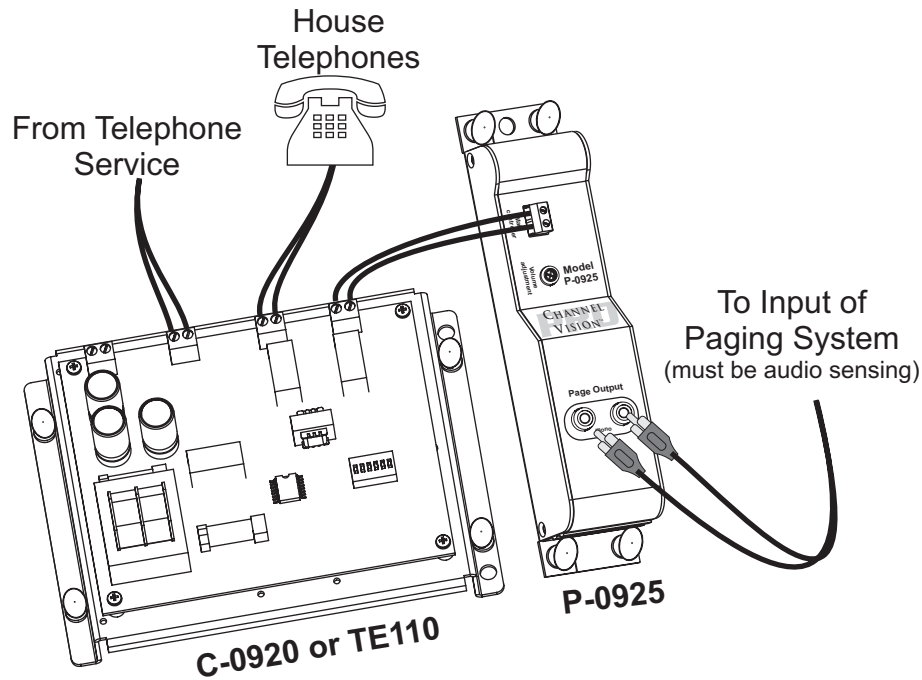

Follow this connection diagram if you only want to have whole-house paging without a front door intercom.

### Additional Notes:

The P-0925 connects to the C-0920 or TE110 the same way one of Channel Vision's DP or IU door stations would. Thus, if a P-0925 is connected to the C-0920, then the a door station cannot be connected. For systems that require both paging and front door intercom, follow the diagram on the next page.

## Paging & Door Intercom

Make all connections before applying power.

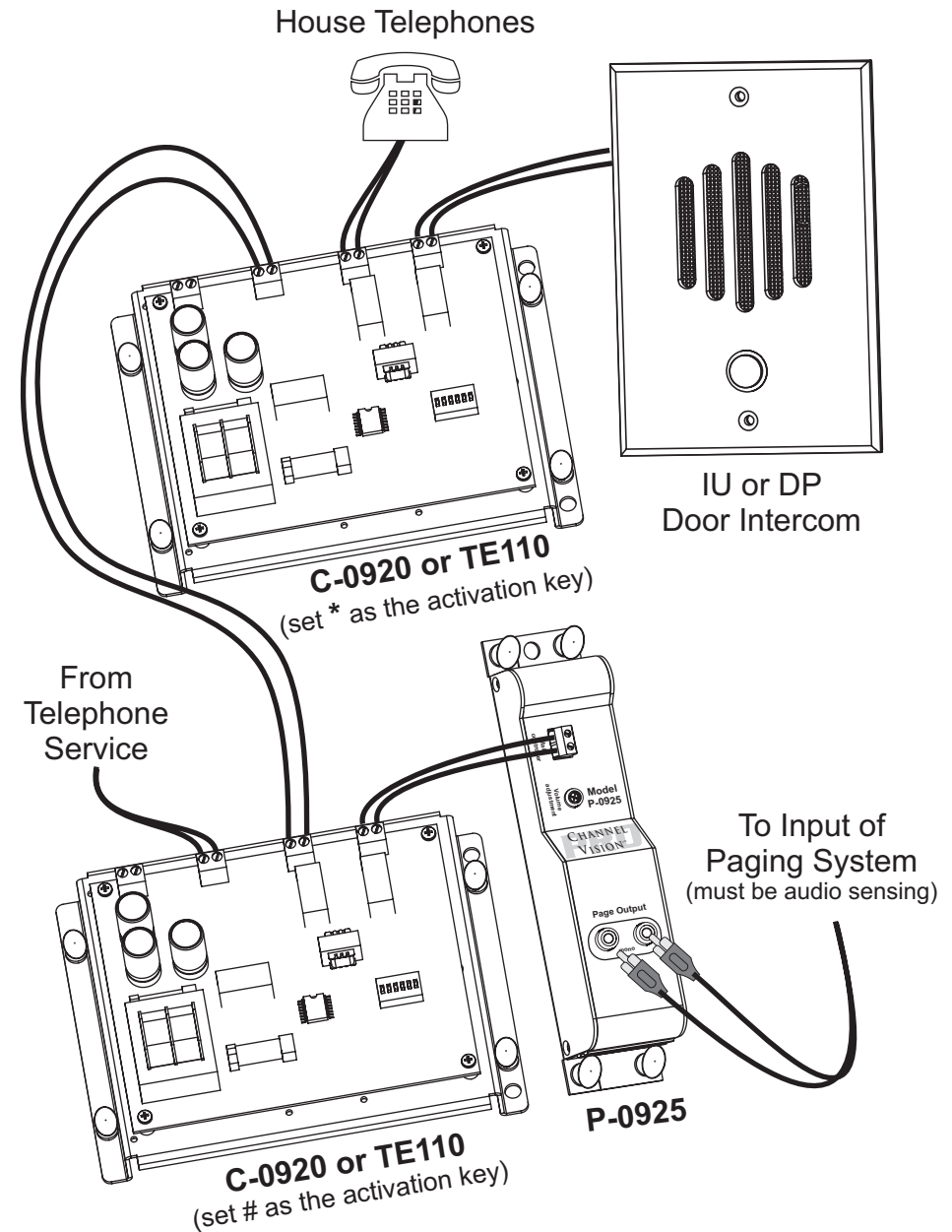

When paging and door intercom are required, two C-0920 or TE110 units must be used and they must be configured to respond to different activation keys. Refer to C-0920 or TE110 manual for help setting the activation key.