

Trouble shooting

The LED does not light:	<ul style="list-style-type: none">• Check the power connection• Check the power supply
The relay does not activate	<ul style="list-style-type: none">• Make sure you are using a valid user card• Make sure the relay is not in toggle mode• Make sure you are using the correct relay output (either N.O. or N.C.)
The relay time is too short	<ul style="list-style-type: none">• Set the door release time longer
Egress button not working	<ul style="list-style-type: none">• Make sure you are using a N.O. switch• Double-check the door release time• Double-check the relay toggle mode

ENFORCER[®] ACCESS

MANUAL PR-112S-A Stand-Alone Proximity Reader

WARNING: Incorrect mounting which leads to exposure to rain or moisture inside the enclosure could cause a dangerous electric shock, damage the device, and void the warranty. Do not open the case of this device, as there are no field-serviceable components inside.

WARRANTY This SECO-LARM product is warranted against defects in material and workmanship while used in normal service for a period of one (1) year from the date of sale to the original consumer customer. SECO-LARM's obligation is limited to the repair or replacement of any defective part if the unit is returned, transportation prepaid, to SECO-LARM. This Warranty is void if damage is caused by or attributed to acts of God, physical or electrical misuse or abuse, neglect, repair, or alteration, improper or abnormal usage, or faulty installation, or if for any other reason SECO-LARM determines that such equipment is not operating properly as a result of causes other than defects in material and workmanship. The sole obligation of SECO-LARM, and the purchaser's exclusive remedy, shall be limited to replacement or repair only, at SECO-LARM's option. In no event shall SECO-LARM be liable for any special, collateral, incidental, or consequential personal or property damages of any kind to the purchaser or anyone else.

NOTICE: The information and specifications printed in this manual are current at the time of publication. However, the SECO-LARM policy is one of continual development and improvement. For this reason, SECO-LARM reserves the right to change specifications without notice. SECO-LARM is also not responsible for misprints or typographical errors. Copyright © 2007 SECO-LARM U.S.A., Inc. All rights reserved. This material may not be reproduced or copied, in whole or in part, without the written permission of SECO-LARM.

SECO-LARM[®] U.S.A., Inc.

16842 Millikan Avenue, Irvine, CA 92606
Tel: 800-662-0800 / 949-261-2999 Fax: 949-261-7326

Website: www.seco-larm.com
E-mail: sales@seco-larm.com



SLI[®]
SECO-LARM[®]

Table of Contents

Introduction	2	Mounting Diagram	5
Specifications	2	Programming	6-8
Parts List	2	Operating Instructions	9
Features	3	System Reset	10
Dimensions	3	List of Users	11
Installation	4	Trouble Shooting	12
Wire Coding	4		

Introduction:

The ENFORCER PR-112S-A Stand-Alone Proximity Reader provides a flexible solution for securing controlled access. The stylish case and small size make it ideal for use in most residential, commercial, and industrial sites. The wave-shaped LED status bar accents the case design. Simple installation, quick programming, high reliability, and great looks are all combined in the PR-112S-A.

Specifications:

Power Input	12VDC
Current Draw	Standby: 80mA @ 12VDC Active: 200mA @ 12VDC
Max. Read Distance	6" (15cm)
User Card Limit	100 cards
Master Card Limit	5 cards
Transmit Frequency	125Khz
Outputs	1 relay (Com, N.O., N.C.)
Contact Rating	1A @ 30V
Relay Time Delay	1~180 secs. / Toggle mode
Temperature	-4°~158°F (-20°~70°C)
Enclosure Rating	IP67
Dimensions	3 ³ / ₁₆ " x 1 ³ / ₁₆ " x 1 ¹ / ₁₆ " (95 x 44 x 17 mm)

Parts List:

- 1 x PR-112S-A Proximity Reader
- 10 x Access Cards (PR-K1S1-A)
- 1 x Installation and Operation Manual

Additional access cards are available. The model number for the cards is PR-K1S1-A.

(Note: Use copy of chart - not original.)

User List:

User	User Name	Card #
1		
2		
3		
4		
5		
6		
7		
8		
9		
10		
11		
12		
13		
14		
15		
16		
17		
18		
19		
20		
21		
22		
23		
24		
25		

System Reset:

Should it be necessary to completely reset the proximity reader, follow this procedure:

1. Disconnect power to the proximity reader.
2. Ground the BLUE wire:
 - 2.1 If the egress button is connected, DO NOT open the case. Just press and hold the egress button.
 - 2.2 If the egress button is not connected, you must unscrew the proximity reader from the wall, and ground the BLUE wire.

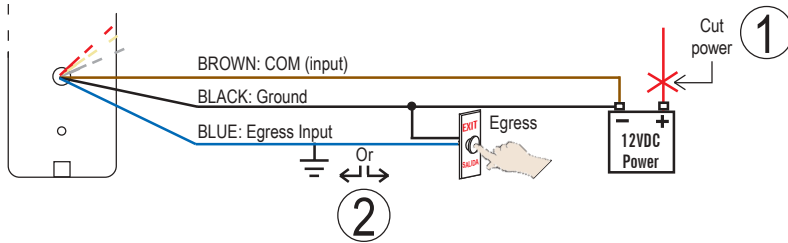

3. While either pressing the egress button or grounding the BLUE wire, reconnect power. The LED will start to blink GREEN. Continue pressing the egress button or grounding the BLUE wire.
4. After about 3 seconds, the proximity reader should sound two long beeps. At this point, release the egress button or unground the BLUE wire.

NOTE: If a mistake is made, just restart this process from step 2 above.

5. After a few seconds, the proximity reader will sound 3 beeps and the LED will start flashing GREEN rapidly. After about 5 seconds, the LED will flash slower. At this point, tap any card to the proximity reader. This is now the first master card.

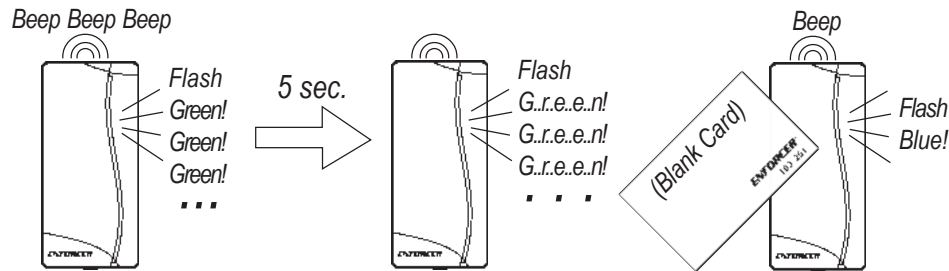

NOTE: After a system reset, all cards except the new master card are now considered to be blank cards.

Features:

- Stand-alone Proximity Card Reader.
- Use in small businesses, homes, parking structures, apartments, and other locations.
- Sealed and weatherproof (IP67). Mounts easily to interior and exterior walls.
- Attractive tri-color wave-shaped LED status bar indicates proximity reader's mode and status.
 - Blue: On/Valid card indicator
 - Green: Programming mode
 - Red: Invalid card
- Output relay for either timed (1 to 180 seconds) or "Toggle" mode.
- Egress input to exit the protected area without using the proximity reader.
- Buzzer is programmable for audible confirmation or silent mode.
- Up to 100 user cards can be programmed.
- User cards easily deleted. Delete a single card, or all cards.
- Up to 5 "Master" cards can be programmed.
- 10 blank cards included.

Dimensions: (Actual size)

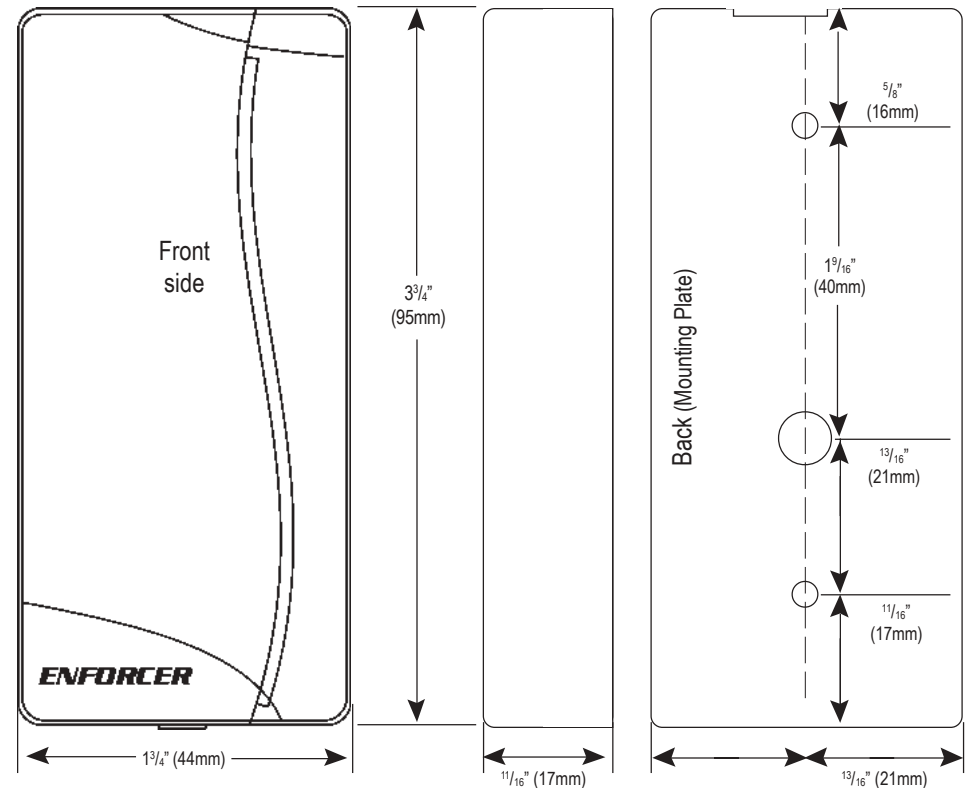

Installation Instructions:

1. Unpack the unit and familiarize yourself with the proximity reader and the included parts.
2. Read this manual from front to back. There is a lot of good information here.
3. Test the mounting location for fit.
4. Using a T-10 Torx driver, remove the screw from the bottom of the proximity reader and separate the outside case from the base.
5. Place the base on the mounting location, and then mark the two mounting holes and the wire harness hole.
6. Drill a 3/4" hole for the proximity reader's wire harness.
7. Permanently screw the base into the mounting location.
8. Run the wires from the power supply, egress button, and door unlock device through the hole to connect to the wire harness.
9. Connect the wires to the proximity reader's wire harness. Solder or crimp the connections, and carefully insulate them.
10. Reattach the outside case to the base.
11. The preliminary installation is done. Now program the proximity reader.

Sample Installation:

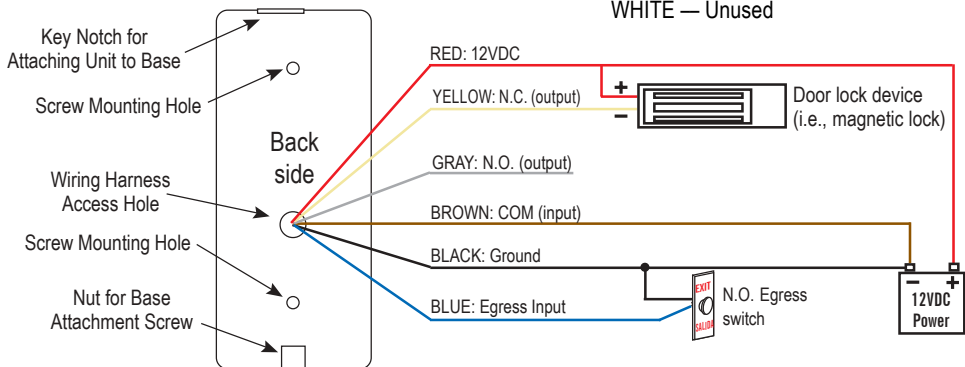

Operating Instructions:

Entering the Premises – User Card

To enter a protected premise, tap the proximity reader one time with a user card. The LED flashes BLUE once, the proximity reader sounds one short beep, and the relay output engages for the programmed time.

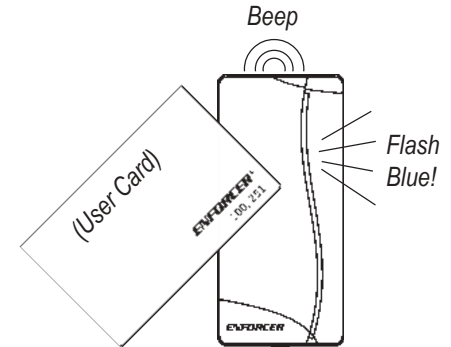

Exiting the Premises – Egress Button

To exit a protected premise, press the egress button once. The LED flashes BLUE once, the proximity reader sounds one short beep, and the relay output engages for the programmed time.

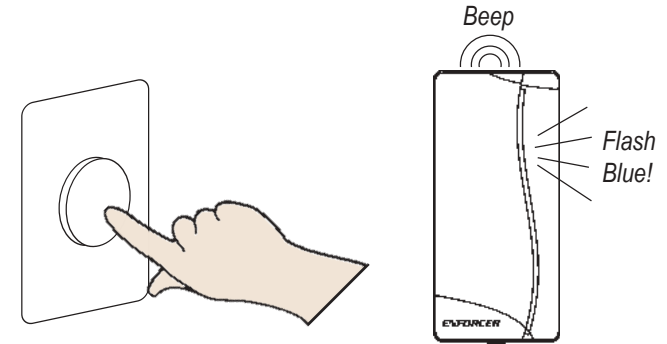

Accidentally Using an Invalid Card

If the proximity reader is tapped using a blank card, the LED flashes RED once and the proximity reader sounds one long beep.

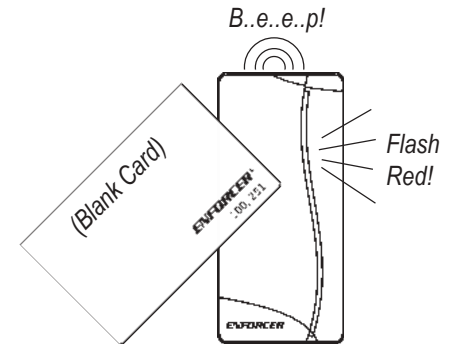

Some examples:

Number of user cards	Beep sequence
13	Long beep / 1 short beep / 3 short beeps
24	Long beep / 2 short beeps / 4 short beeps
7	Long beep / Long beep / 7 short beeps
100	1 short beep / Long beep / Long beep

8. Set the relay toggle mode (timed output or latched on/off)

Action	Reaction
Tap a master card 8 times	2 quick beeps, 7 more beeps
Wait 3 seconds	8 beeps, green flashes continue
Wait a second, and the mode	Beeps 1 time = normal mode
Changes automatically	Beeps 2 times = latched mode
The unit automatically exits to standby mode	

Normal mode -- Use a user card to unlock the door, the door automatically locks after the timer expires.

Latched mode -- Use a user card to unlock the door, and then use a user card to relock the door.

9. Not used, reserved for future use

10. Set the beeper mode (to beep or not when a user card is used)

Action	Reaction
Tap a master card 10 times	2 quick beeps, 9 more beeps
Wait 3 seconds	10 beeps, green flashes continue
Wait a second, and the mode	Beeps 1 time = beeper off
Changes automatically	Beeps 2 times = beeper on
The unit automatically exits to standby mode	

NOTE -- When the beeps are programmed off, the proximity reader will still beep during the programming mode.

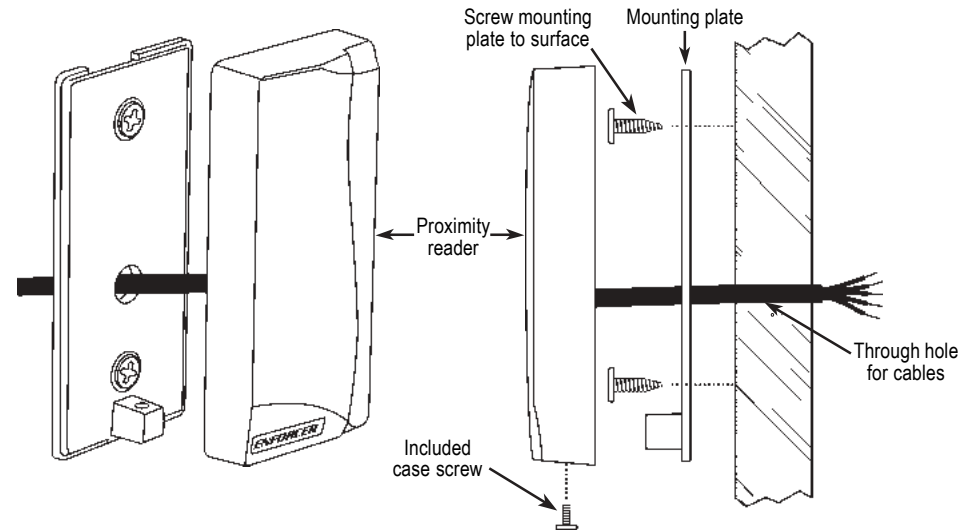

Card Types:

There are three basic types of cards used by the proximity reader:

- Master Card (MC) – Used for programming only. It does not give access to the protected premises.
- User Card (UC) – Used for access only. Considered to be a valid card.
- Blank Card (BC) – A card that has not yet been programmed into the proximity reader. Considered to be an invalid card.

NOTE – The proximity reader can learn up to 5 master cards and 100 user cards.

LED Color Meanings:

LED Color What it means

Blue The proximity reader is powered on and in the standby mode

Green The proximity reader is in the programming mode

Red Indicates an error

First Time Power Up:

1. After connecting power the unit should beep once and the LED should be **Blue** - The Proximity Reader is ready to be programmed using the included MC (Master Card) marked with a MC sticker.
2. If after connecting power for the first time the LED is flashing **Green** you must program your MC (Master Card) by tapping it to the reader.
3. This will be followed by 2 short beeps and the LED should turn **Blue**.
4. The Proximity Reader is ready to be programmed using the MC (Master Card) you just created.

1. Add a new user card

Action	Reaction
Tap a master card 1 time	2 quick beeps, LED flashes green
Wait 3 seconds	1 beep, green flashes continue
Tap a blank card 1 time	1 beep, the card is now a user card
Tap more blank cards 1 time each to create more user cards	1 beep for each new user card
Exit - To exit programming mode, tap a Master Card 1 time or wait 15 seconds.	

NOTE -- Attempting to add a previously-learned user card or master card will cause the unit to beep and LED to flash red.

2. Delete the user card following this user card

Use this to delete a user card that was not returned by an employee

Action	Reaction
Tap a master card 2 times	2 quick beeps, 1 more beep, LED flashes green
Wait 3 seconds	2 beeps, green flashes continue
Tap the user card that was added just before the card to be deleted	2 quick beeps, the desired user card is deleted
Exit - To exit programming mode, tap a Master Card 1 time or wait 15 seconds.	

NOTE -- Attempting to delete a blank card or a master card will cause the unit to beep and LED to flash red.

3. Delete this user card

Use this to delete a user card that is in your possession

Action	Reaction
Tap a master card 3 times	2 quick beeps, 2 more beeps, LED flashes green
Wait 3 seconds	3 beeps, green flashes continue
Tap the user card to be deleted	3 quick beeps, the user card is deleted
Exit - To exit programming mode, tap a Master Card 1 time or wait 15 seconds.	

NOTE -- Attempting to delete anything other than a user card will cause the unit to beep and LED to flash red.

4. Delete all user cards

Action	Reaction
Tap a master card 4 times	2 quick beeps, 3 more beeps, LED flashes green
Wait 3 seconds	4 beeps, green flashes continue

WITHIN 3 SECONDS, tap the master card again
4 quick beeps, all user cards are deleted
The unit automatically exits to standby mode

5. Add a new master card

Action	Reaction
Tap a master card 5 times	2 quick beeps, 4 more beeps, LED flashes green
Wait 3 seconds	5 beeps, green flashes continue
Tap a blank card or a user card	2 beeps, the card is now a master card
Tap more blank or user cards 1 time each to create more master cards	2 beeps for each new master card
Exit - To exit programming mode, tap a Master Card 1 time or wait 15 seconds.	

6. Set the door release timer

Action	Reaction
Tap a master card 6 times	2 quick beeps, 5 more beeps, LED flashes green
Wait 3 seconds	6 beeps, green flashes continue
Count the beeps	1 beep = 1 second for the door release timer
Tap the master card to stop the beeps equal to the number of beeps	The timer is now set for the number of seconds
The unit automatically exits to standby mode	

7. Show me how many user cards have been programmed

Action	Reaction
Tap a master card 7 times	2 quick beeps, 6 more beeps
Wait 3 seconds	7 beeps, green flashes continue
Wait 1.5 seconds	Silence
Count beeps for the first digit	Long beep=0 or 1 beep=1
Wait 1 second	Silence
Count beeps for the second digit	Long beep=0 or 1-9 beeps
Wait 1 second	Silence
Count beeps for the third digit	Long beep=0 or 1-9 beeps
The unit automatically exits to standby mode	

Counting the beeps -- The number of beeps indicates the value of each digit. All three digits together gives the number of user cards that have already been programmed.