

ENFORCER[®] VIDEO

MANUAL DP-121Q Video Door Phone



The ENFORCER DP-121Q Video Door Phone is the easy, secure way to identify visitors. Suitable for home or business use, the ENFORCER DP-121Q Video Door Phone can be installed at doors or entrances. A crisp image of the visitor is shown in real-time on the phone's monitor, while the camera's built-in LEDs provide a clear image even in low-light conditions. A built-in microphone and speaker on the camera unit lets users communicate with visitors. Authorized visitors can then be granted entry with a push of a single button.

SLI[®]
SECO-LARM[®]

FC  **CE**

Table of Contents

Features	2	Operating Instructions	7
Specifications	2	LED Indicator	8
Parts List	2	Dimensions	8
Overview	3	Sample Application	9
Installation Notes	4	Additional Accessories	9
Installation (monitor)	4	Wiring Diagram	10
Installation (camera)	6	Troubleshooting	12

Features:

- Camera has 6 LEDs for nighttime operation.
- Remotely and securely talk to visitors and unlock doors, gates, etc. from the monitor.
- Easily connect an additional monitor and/or an additional camera.
- Built-in microphone: Talk and listen to visitors at the same time.
- Camera contains built-in angle adjustment.
- Simple 4-wire connection.
- Easy surface-mount installation.
- Camera and monitor turn on and off with the push of a button.
- Camera and monitor turn off automatically when not in use.
- Adjustable contrast, brightness, and ringer volume.
- LED indicators for power and operation.

Specifications:

Camera	
Type	B/W Camera
Chip	CCD
Resolution	380 TV lines
Relay output	1 Amp@12VDC max. dry contact
Lens	3.6mm
Min. illumination	0.8 Lux
Weight	8 oz. (220g)
Dimensions	5 ¹ / ₄ " x 3 ¹⁵ / ₁₆ " x 1 ¹ / ₂ " (134 x 100 x 38 mm)

Monitor	
Display	CRT
Weight	2 lb. 8 oz. (1.1kg)
Power consumption	800mA@15~18 VDC
Power source	15VDC +/- 15%
Dimensions	9 ⁵ / ₈ " x 7 ¹¹ / ₁₆ " x 3 ¹ / ₈ " (245 x 196 x 79 mm)

Parts List:**DP-121Q Contains:**

Camera	x 1
Camera bracket	x 1
Screws	x 8
Screw anchors	x 8
Crimp-on terminals	x 6
Camera screw	x 1
Monitor	x 1
Monitor Bracket	x 1
AC Power Adapter	x 1
Molex wiring harness	x 2

DP-121SQ Contains:

Monitor	x 1
Monitor Bracket	x 1
AC Power Adapter	x 1
Molex wiring harness	x 1
Screws	x 4
Screw anchors	x 4

DP-121CQ Contains:

Camera	x 1
Camera Bracket	x 1
Molex wiring harness	x 1
Camera screw	x 1
Screws	x 4
Screw anchors	x 4

Overview:

Monitor

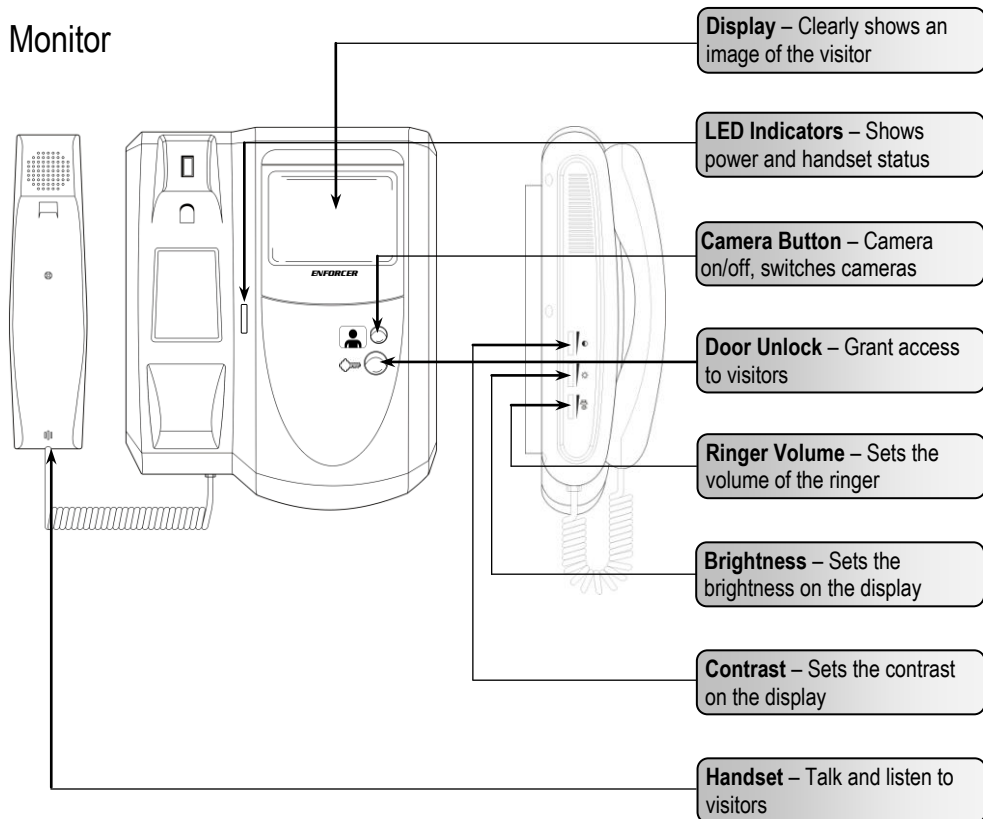

Camera

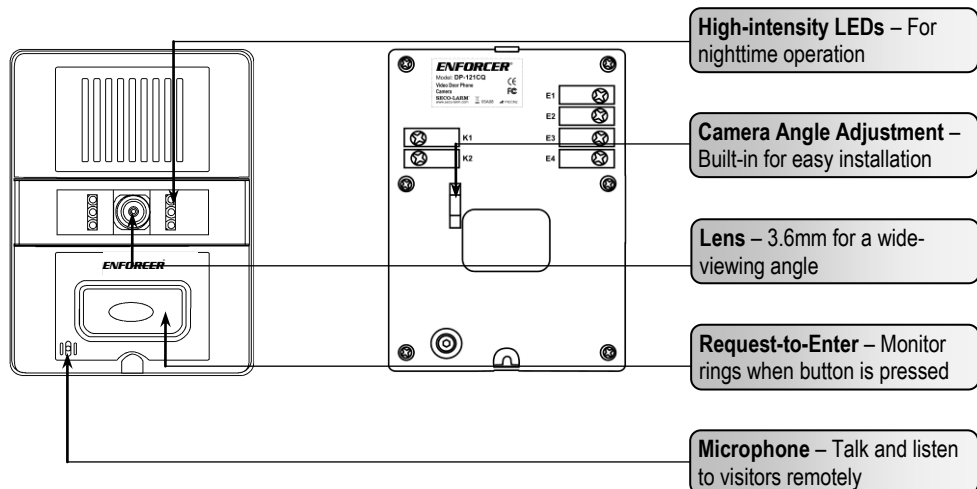

Installation Notes:

1. Unpack the video door phone and note the included parts.
2. Read this manual thoroughly. A clear understanding of the manual will make installation and operation much easier.
3. Find a good location to mount the monitor and camera. Make sure there is enough room to wire both units correctly with 22AWG 4-conductor wire.
4. Use only untwisted-pair wire; twisted-pair wire may cause interference.
5. Avoid mounting either the cameras or the monitors near sources of strong electromagnetic signals or other electronic devices as they may cause interference.
6. Avoid mounting the cameras in direct sunlight or exposing the camera to strong vibrations or direct rain or other moisture, as it may damage them.
7. The camera and the monitor contain no user-serviceable parts. Opening them may damage sensitive components and void the warranty.

Installation (monitor):

1. The monitor must be positioned so that the image can be seen clearly and the user can operate the monitor's functions.
2. Use the mounting bracket as a template to pencil in where to drill the holes for the mounting bracket screws.
3. Drill the mounting bracket holes as needed. Drill a hole large enough to fit the 22AWG 4-conductor wire which will run through the wall from the camera to the monitor (see Figure 1).
4. Using the 4 included screws and 4 screw anchors, attach the monitor bracket to the wall, running the cable through the large hole in the mounting bracket.
5. Plug the brown 4-pin plastic connector from the camera into the "Camera 1" socket (see Figure 2).
NOTE: If using only one monitor and camera, there will be unused sockets on the back of the monitor.

Figure 1 – Monitor Mounting Bracket

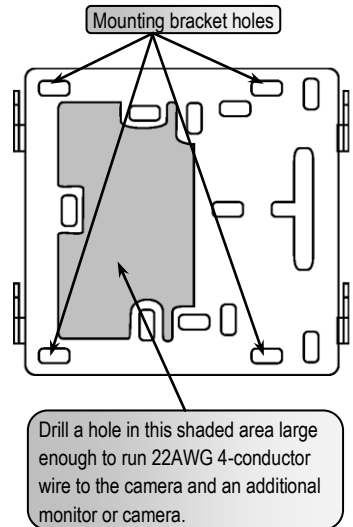

6. Plug the AC Power Adapter's cable into the "Power" socket on the back of the monitor.
7. Run the wires going to the camera under the plastic hooks on the back of the monitor so that any tension on them will not be directly transferred to the plugs or sockets.
8. Plug the AC power adapter into a 120VAC socket.
9. Test the monitor and camera unit by pressing the camera button. The image in front of the camera should be displayed clearly.

Figure 2 – Back of Primary Monitor Detail

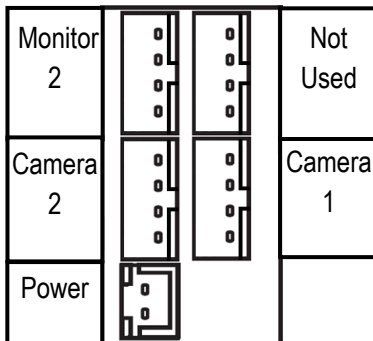

Camera 2 and Monitor 2 sockets are used only with optional additional monitor and camera.

Installing a Second Monitor:

10. If using a secondary monitor, follow steps 1-4 on page 4.
11. Plug the brown 4-pin plastic connector from the camera into the "Main Monitor" socket (see Figure 3).
NOTE: There will be and unused socket on the back of the secondary monitor.
12. Follow steps 6-9 above to complete the installation

Figure 3 – Back of Secondary Monitor Detail

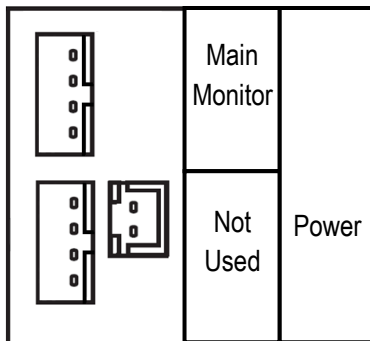

Installation (camera):

1. Position the camera so the area to be monitored is easily visible, typically 5 feet (150cm) above the ground (see Figure 3). Do not position the camera in direct sunlight or where it will be exposed directly to rain or snow.
2. Cut a hole large enough to run the 22AWG 4-conductor wire through the wall to where the camera unit is to be mounted. If using a locking device, the wires used to control the device must also be run through this hole.
3. Run the 22AWG 4-conductor wire from the camera location to where the monitor is mounted. The maximum wiring distance is 165' (50m) (see Wiring Diagram, page 8).
4. Using the 4 included screws and 4 screw anchors, attach the camera mounting bracket to the wall (see Figure 4).
5. Connect the wires coming from the monitor to the proper terminals E1 through E4 on the back of the camera (see Figure 5).
6. If the Door Phone will control a locking device, connect the wires coming from the locking device to the relay output terminals K1 and K2 on the back of the camera (see the Sample Application on page 11).
7. Set the desired camera angle up and down by moving the tilt adjustment in the opposite direction.
8. Push the tab on top of the camera into the top of the bracket. Make sure that no wires are preventing the camera from seating properly in the bracket. Pull the slide-out cover to expose the hidden screw location.
9. Secure the camera to the mounting bracket with the included camera screw. Close the cover at the bottom of the camera to conceal the camera screw.

Figure 4 – Camera Mounting Location

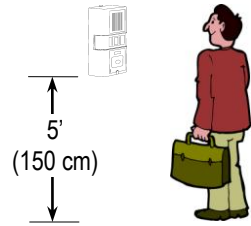

Figure 5 – Camera and Mounting Bracket

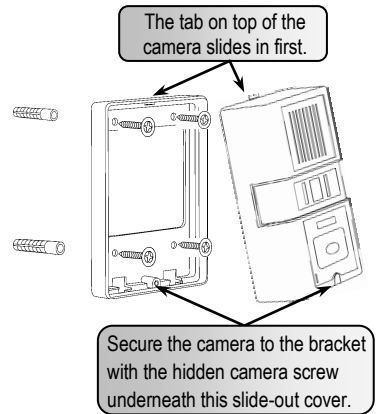
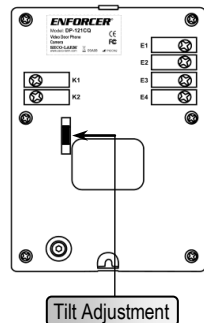

Figure 6 – Rear of Camera Unit



Operating Instructions:

1. When the request-to-enter button on the camera is pressed, the monitor will ring twice. After ringing, any connected monitors will switch on.
2. When the handset is picked up, audio can be heard through the handset.
NOTE: If two monitors are connected, the monitor that does not answer the call will turn off.
3. If the optional additional camera is installed, pressing the Camera Button will switch the image displayed on the monitor to the view from the other camera. Pressing the camera button again will turn off the cameras.
4. The monitor is automatically switched off after the handset is hung up, 1 minute of inactivity pass, or the Camera Button is pressed.



Camera Button

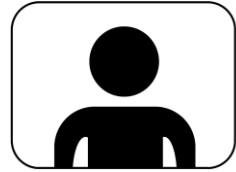

If connected to a door strike or other locking device:

See the Wiring Diagram on Page 8 for more details.

To allow access to the entrance, press the Unlock Button. This signals the door strike or lock to allow entry.

Unlock Button



IMPORTANT: The door strike or lock will only remain unlocked while the Unlock Button is pressed.

For Example:

If the entrance door is located a few steps from the camera, the Unlock Button must be pressed long enough to give the visitor enough time to open the entrance.



Operating Instructions (cont):

Monitoring the entrance:

1. To see and hear what is going on at the entrance, lift the handset and press the Camera Button. The camera and monitor will automatically switch on.
2. If the optional additional camera is installed, pressing the Camera Button a second time will switch the image displayed on the monitor to the view from the other camera. Pressing the camera button again will turn off the cameras.
3. When finished, simply hang up the handset and the camera will switch off. If the handset is not hung up, the camera will automatically switch off after 2 minutes.

Camera Button

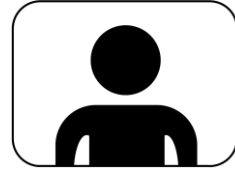

LED Indicator:

A status LED indicator is located on the front of the monitor. The LED displays power information as well as the status of the handset.

LED Indicator



Green LED – Solid green LED indicates standby mode. Flashing green LED indicates camera “on”. (2 monitors only)

Red LED – Solid red LED indicates standby mode. Flashing red LED indicates camera “on”.

Dimensions:

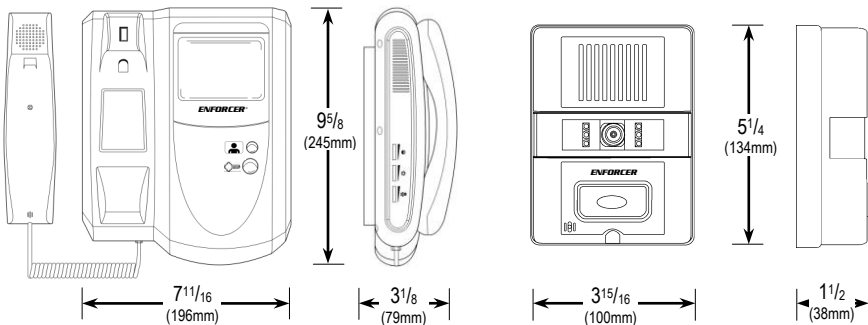

Sample Application:

Up to 2 monitors can be connected to 1 or 2 cameras:

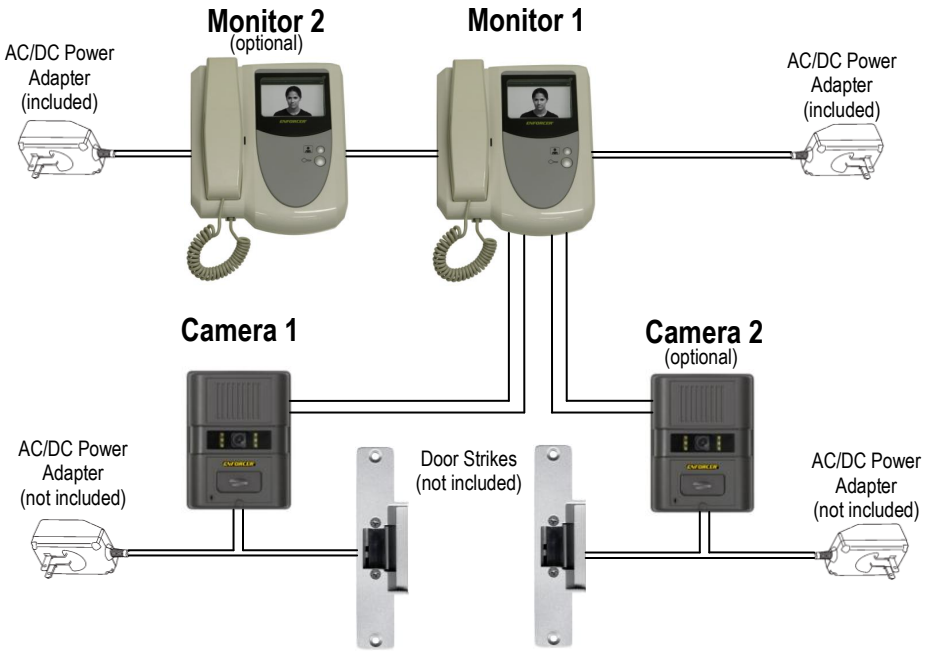

Additional Accessories Available from SECO-LARM:

The **DP-121Q** Video Door Phone can be expanded to connect an additional monitor and an additional camera.

DP-121SQ - Additional Video Door Phone Monitor

DP-121CQ - Additional Video Door Phone Camera

- Connect 2 monitors to 1 or 2 cameras.
- Remotely unlock 2 protected entrances.
- Extra monitor and camera are easily installed with a single connection.



SECO-LARM carries a complete line of security products.

Please visit www.seco-larm.com for more information.

Wiring Diagram – Connecting to an Electric Doorstike:

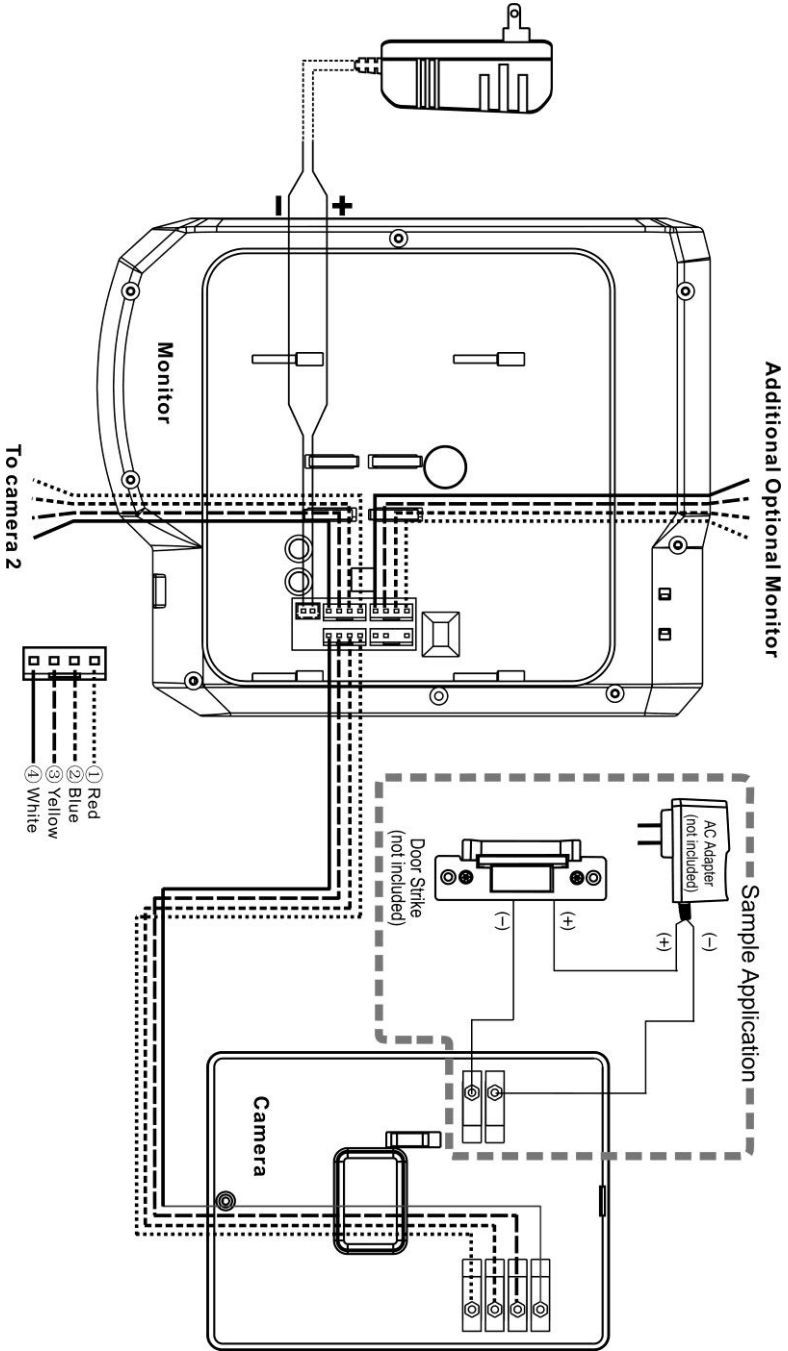

Wiring Diagram – Connecting to an Electric Doorstike:

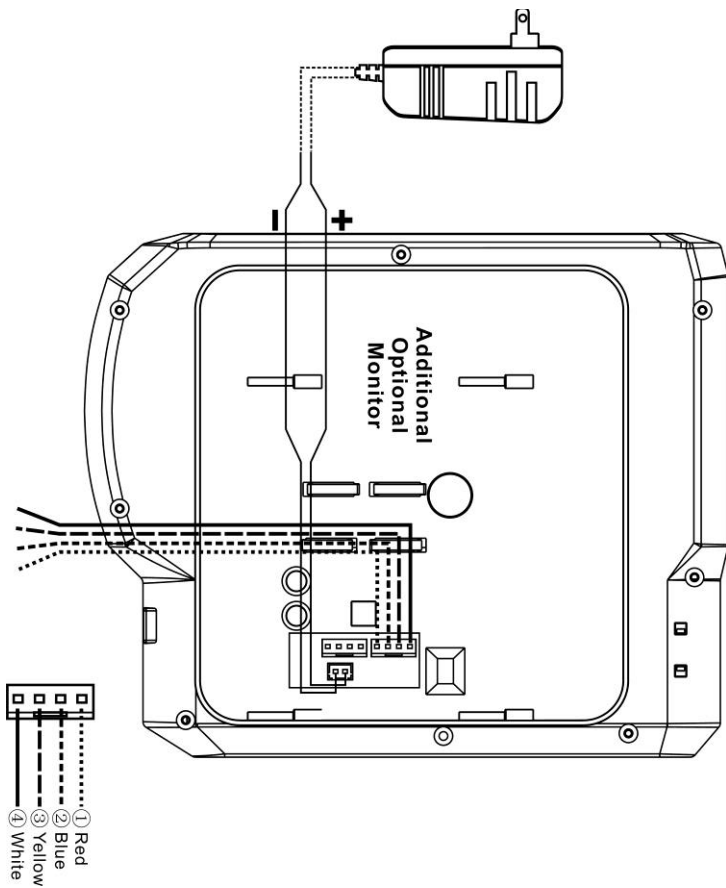

Note: Professional installation recommended

Troubleshooting:

The screen displays no image	<ul style="list-style-type: none">• Check that the camera is powered up• Check that the monitor is powered up• Check that the power supply's polarity is correct• Check that the video cable connecting the camera to the monitor is connected properly
The image is displayed incorrectly	<ul style="list-style-type: none">• Adjust the angle and/or location of camera
The image has poor contrast	<ul style="list-style-type: none">• Adjust the contrast on the phone
The screen image is dim	<ul style="list-style-type: none">• Clean the lens using a soft, clean cloth• Adjust the brightness on the phone
The phone does not ring when request-to-enter button is pressed	<ul style="list-style-type: none">• Adjust the ringer volume on the phone

IMPORTANT

Users and installers of this product are responsible for ensuring this product complies with all national, state, and local laws and statutes related to monitoring and recording audio and video signals. **SECO-LARM** will not be held responsible for the use of this product in violation of any current laws or statutes.

WARNING

Stop using the camera if there is a malfunction like smoke or unusual heat, as that could cause a fire or electric shock. Do not open the case of this device, as there are no field-serviceable parts inside.

FCC COMPLIANCE STATEMENT

Information to the user: This device is in conformance with Part 15 of the FCC Rules and Regulations for Information Technology Equipment. Operation of this product is subject to the following two conditions: (1) this device may not cause harmful interference, and (2) this device must accept any interference received, including interference that may cause undesired operation.

WARRANTY This SECO-LARM product is warranted against defects in material and workmanship while used in normal service for a period of one (1) year from the date of sale to the original consumer customer. SECO-LARM's obligation is limited to the repair or replacement of any defective part if the unit is returned, transportation prepaid, to SECO-LARM. This Warranty is void if damage is caused by or attributed to acts of God, physical or electrical misuse or abuse, neglect, repair, or alteration, improper or abnormal usage, or faulty installation, or if for any other reason SECO-LARM determines that such equipment is not operating properly as a result of causes other than defects in material and workmanship. The sole obligation of SECO-LARM, and the purchaser's exclusive remedy, shall be limited to replacement or repair only, at SECO-LARM's option. In no event shall SECO-LARM be liable for any special, collateral, incidental, or consequential personal or property damages of any kind to the purchaser or anyone else.

NOTICE: The information and specifications printed in this manual are current at the time of publication. However, the SECO-LARM policy is one of continual development and improvement. For this reason, SECO-LARM reserves the right to change specifications without notice. SECO-LARM is also not responsible for misprints or typographical errors. Copyright © 2008 SECO-LARM U.S.A., Inc. All rights reserved. This material may not be reproduced or copied, in whole or in part, without the written permission of SECO-LARM.

Made in China

SECO-LARM U.S.A., Inc.[®]

16842 Millikan Avenue, Irvine, CA 92606

Tel: 800-662-0800 / 949-261-2999 Fax: 949-261-7326

file: DP-121Q_VDP_manual.docx

Website: www.seco-larm.com

PICCN2

E-mail: sales@seco-larm.com