



SENTROL

2315 Series Panel Door Magnetic Contact

Installation Instructions

Models: 2315A-L, 2315-L, 2317A-L,
2317AH-L, 2317H-L, 2317-L



Patent Pending

Mounting

Caution: Locate the magnet away from manual handles and latches to prevent it from being used as a foothold or handle to close the door.

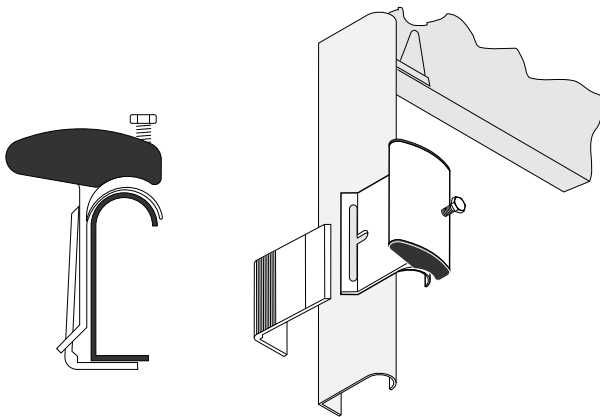

Figure 1

1. Slide the slot of the switch over the beveled-edge of the L-bracket and snap it tightly into place as shown in Figure 1. Screw down firmly.

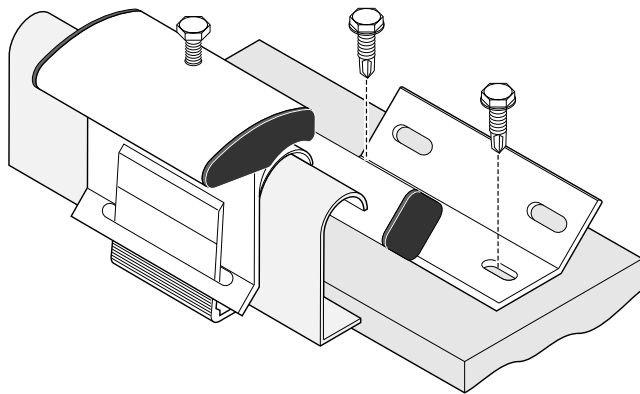

Figure 2

2. Align the magnet with the switch and use screws to attach it to the door as shown in Figure 2. The switch and magnet must be aligned within 1/2 inch of each other to prevent false alarms near intermediate alarm regions.

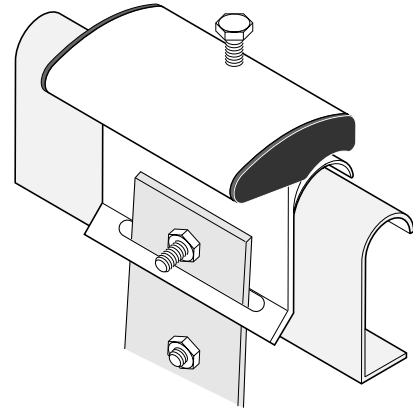
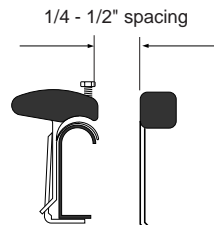
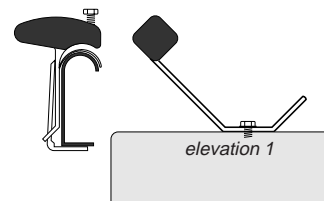

Figure 3

Optional: Use the existing roller-track bolts to mount the switch without using the L-Bracket as shown in Figure 3.

3. Connect the switch wires to the alarm system and test to verify proper operation.

Important: The contact should be mounted at least 13 inches from the floor. If other track-mounted devices interfere, mount the switch under them.



The magnet can be attached at two different elevations from the door.

Fits standard 2" roller-tracks for sectional/panel overhead doors.

Figure 4

Dimensions

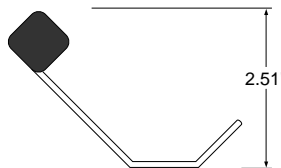
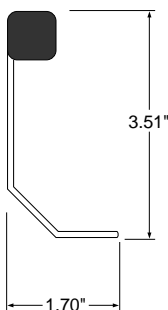
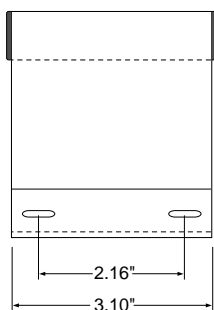
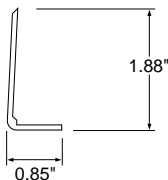
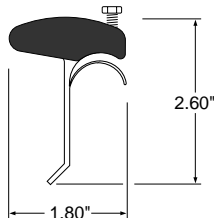
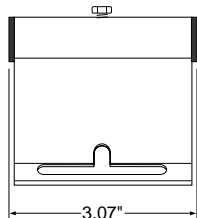
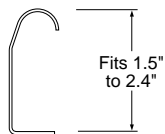

Specifications

General

The contact shall be a hermetically sealed reed switch nominally 3.07H x 1.80W x 2.60D with actuating magnet. Contact and magnet shall be in extruded aluminum type housing. Contact shall be sealed in Sentrol's exclusive polyurethane potting compound. Mounting bracket shall be furnished with contact. Contacts shall be specified as Sentrol part numbers 2315 and 2317. Contact is designed for installation on metal overhead door tracks.

Specifications

Form A (2315)

Voltage

100 V AC/DC max.

Current

0.5 A max.

Power

7.5 W max.

Form C (2317)

Voltage

30 V AC/DC max.

Current

0.25 A max.

Power

3.0 W max.

Ordering Information

Model Number	Loop Type	Electrical Configuration	Gap Distance (Make)*	Lead Type	Listing
2315	Closed	NO	Up to 3"	2' vinyl jacketed	UL, ULC
2315A	Closed	NO	Up to 3"	2' stainless steel armored cable	UL, ULC
2317	Open or closed	SPDT	Up to 3"	2' vinyl jacketed	UL, ULC
2317A	Open or closed	SPDT	Up to 3"	2' stainless steel armored cable	UL, ULC
2317AH	Open or closed	SPDT	3/4" to 2 1/2"	2' stainless steel armored cable	UL
2317H	Open or closed	SPDT	3/4" to 2 1/2"	2' vinyl jacketed	UL

Note: *Gap distances are nominal make distance $\pm 20\%$. Gap specifications are for switch to make.

Break distance is approximately 1.1 to 1.5 times make.

Patent pending.

* European Union Specification: 48 V AC/DC Max., 0.5 Amp



SENTROL

CORPORATE HEADQUARTERS

12345 SW Leveton Dr., Tualatin, OR 97062

Tel.: 503.692.4052 Fax: 503.691.7566

<http://www.sentrol.com>

U.S. & Canada: 800.547.2556

Technical Service: 800.648.7424

FaxBack: 800.483.2495

Sentrol reserves the right to change specifications without notice.

©1999 Sentrol

C-3598-0299
15554 Rev. B