

## Installation

1. A single M1RB Output Relay Board can be mounted inside the M1 enclosure on the left hand side of the M1 board using the supplied ELK-SWG Circuit Board Glides. Additional relay boards and/or expanders must be mounted in either an ELK-SWB14 or ELK-SWB28 enclosure. Up to 8 Relay Boards/Expanders can be mounted in an SWB14 while up to 16 can be mounted in an SWB28.

The ELK-SWG Circuit Board Glides attach to the enclosure at strategically placed 2-hole punch patterns. Note that one hole in each pattern is slightly larger than the other. The small hole is for a 6/32 type "F" mounting screw and the large hole is for a half-moon shape locator tab on the bottom of each glide.

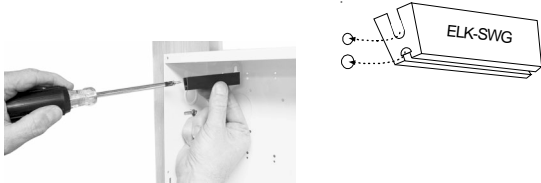

2. Starting at the top left corner, loosely start a 6/32" mounting screw in the small hole of the first 2-hole pattern. Place the slotted edge of a board glide under this screw, making sure that the half-moon tab fits into the larger hole and the grooved edge is facing down. Tighten the screw using a long shafted screwdriver. Install a second board glide in the 2-hole pattern located 6" below. Attach the second board glide using the same procedures. The grooved edge of this glide should face up.
3. Slide the M1RB Relay board into the grooves provided by the glides. The circuit board should slide freely. If the board is loose or too tight, simply loosen one of the mounting screws and adjust the glide to assure a good fit.

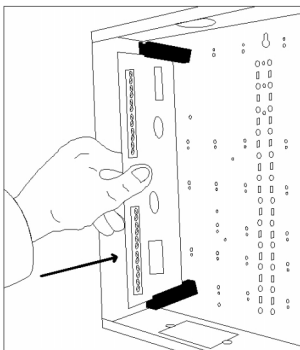

## Wiring Connections

1. Turn Off the M1 Master Power Switch.
2. Connect one end of the 12 conductor ribbon cable (provided) into connector J1 on the M1RB.
4. Connect the other end of the 12 conductor cable to the connector J16 of the control. Note: If the M1RB is being used with an M1XOVR Output Expander the connector is marked J3. If being connected to an M1XOV there are two connectors, J3 and J4. J3 provides the 2nd group of 8 outputs while J4 provides the 1st group of 8 outputs.

Continued on next page...

# Output Relay Board ELK-M1RB

## APPLICATION:

The **ELK-M1RB** works with an M1 or M1G Control, or with an M1XOV or M1XOVR Output Expander, for converting the low current (50mA) voltage outputs into SPDT relay outputs. When used with an M1 Control, the M1RB also provides voltage outputs 7 & 8, which are ordinarily not available. Up to 2 M1RBs may be connected to an M1XOV (voltage only) Output Expander.

**ELK**  
PRODUCTS, INC.

## Output Relay Board ELK-M1RB



## FEATURES:

- 8 Form "C" Relays, SPDT Dry Contact
- Heavy Duty Contact Rating
- Low Current Draw.
- Great For General Purpose Switching.
- Plug-in "Removable" Terminal Blocks
- LED Status Indicators on all 8 Relays
- Twelve (12) Conductor Plug-in Wire Harness
- Mounts in Enclosure using ELK-SWG Glides

## SPECIFICATIONS:

- Diode Protection Across Relay Coil.
- Relay Contact Ratings:
  - 7 Amps @ 28 VDC, 10 Amps @ 125 VAC \*
- Wire Harness Length: 24"
- Operating Voltage: 12 Volts DC Nominal
- Current Draw: 0 mA idle, 250 mA Max.
- Size: 6" x 3.25" x .75" H

\* For UL listed installations the maximum contact ratings are 4 Amps @ 12 VDC

Features or Specifications subject to change without notice.

**ELK**  
PRODUCTS, INC.

828-397-4200 Voice  
828-397-4415 Fax  
<http://www.elkproducts.com>  
email: [info@elkproducts.com](mailto:info@elkproducts.com)

PO Box 100 • Hwy. 70W • Hildebran, NC 28637 • USA



# ELK-M1

Control Panel Lower Right Side

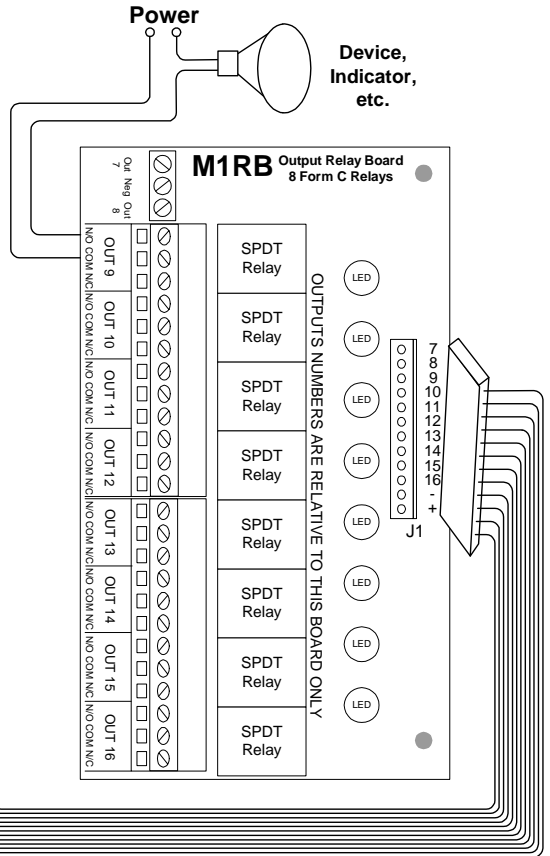
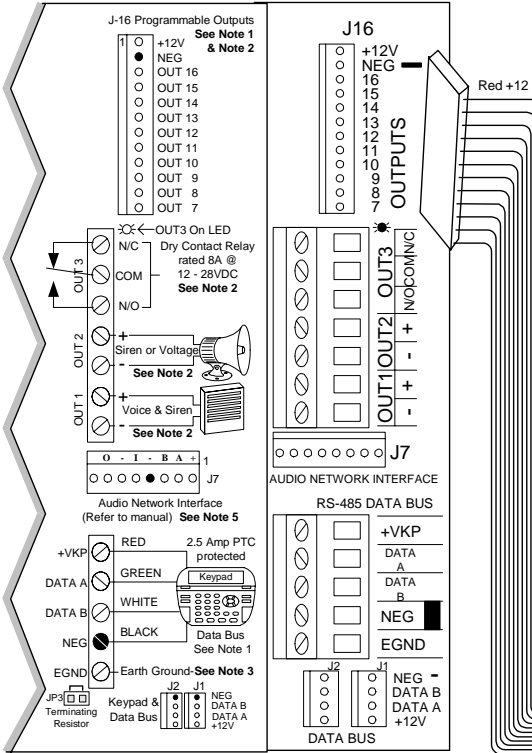

## Connecting an ELK-M1RB to J16 on the ELK-M1 Control

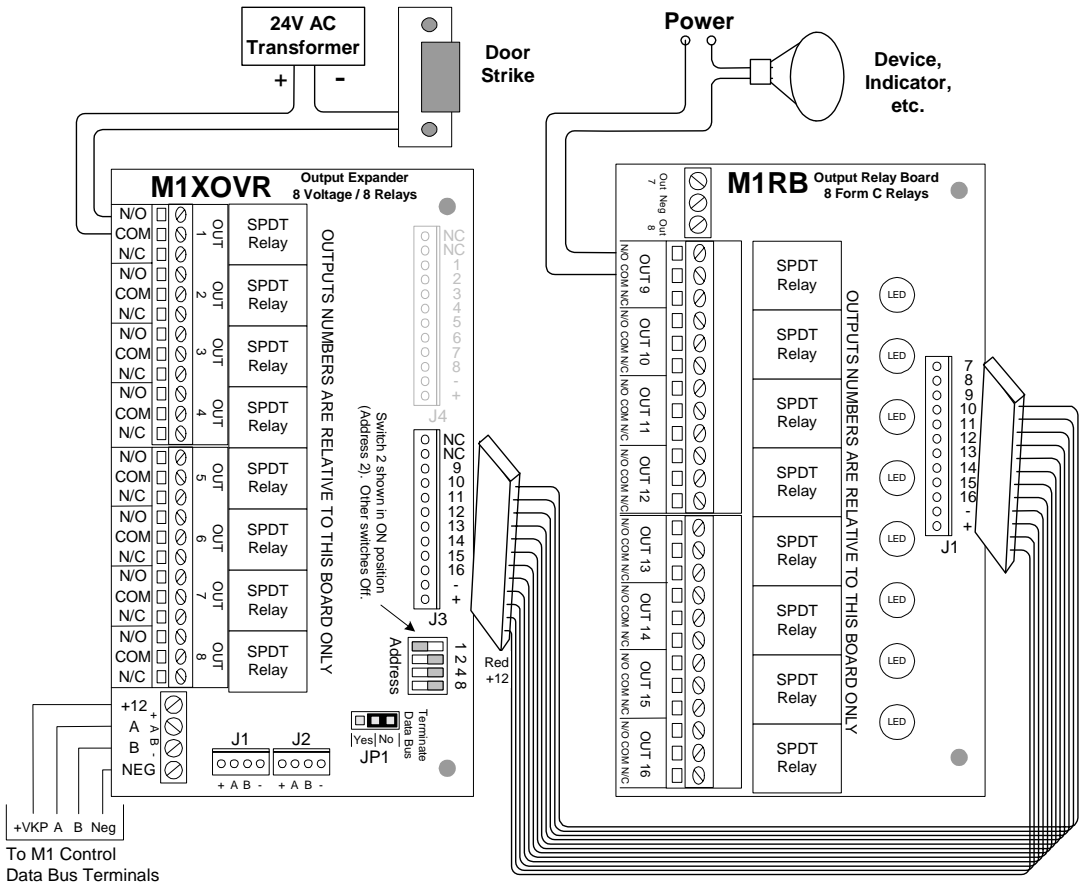

## Adding an ELK-M1RB to a ELK-M1OVR Output Expander

**NOTE** Should all relays be activated at the same time, the combined current draw of an M1RB can be over 240mA. This must be figured into the maximum combined current available from the M1 Control. If an M1RB is connected to an M1XOV or M1XOVR Output Expander, the additional current draw from these devices must be calculated as well.