

INSTALLATION

WARNINGS AND CAUTIONS:

- TO BE INSTALLED AND/OR USED IN ACCORDANCE WITH APPROPRIATE ELECTRICAL CODES AND REGULATIONS.
- IF YOU ARE NOT SURE ABOUT ANY PART OF THESE INSTRUCTIONS, CONSULT AN ELECTRICIAN.
- ROOM CONTROLLERS ARE INTENDED ONLY FOR USE INDOORS, IN DRY LOCATIONS, AND WITH PERMANENTLY INSTALLED FIXTURES.
- ROOM CONTROLLERS SHOULD NOT BE INSTALLED IN LOCATIONS WHERE THE UNITS WILL BE IN CLOSE PROXIMITY TO LIGHT BULB(S) OR OTHER SOURCES OF HEAT, SUCH AS ABOVE A CEILING HUGGER FIXTURE, PARTICULARLY WITH HIGHER WATTAGE LOADS. (SEE "OPERATING TEMPERATURE" ON SPECIFICATIONS TABLE).
- INSTALLATION IN METALLIC ENCLOSURES OR NEAR LARGE METAL OBJECTS WILL TYPICALLY REDUCE RADIO RANGE. IF POSSIBLE, INSTALL IN PLASTIC OR FIBERGLASS ENCLOSURES FOR BEST PERFORMANCE.

DESCRIPTION:

The Room Controller provides fast and simple installation of remote controls for lighting, HVAC, motor, and other loads. The receiver responds to radio signals from self-powered wireless light switches and other compatible transmitters, providing control to multiple outputs. The relay receiver can be used in single pole, 3-way, or 4-way switch applications. The WS0RC-300 and WS0RC-200 models also allow wired motion and occupancy sensors to control a wireless Leviton receiver network.

COMPATIBLE DEVICES:

- Key Card Access Switch
- Single Rocker Self-powered Wireless Light Switches
- Dual Rocker Handheld Remote
- Dual Rocker Self-powered Wireless Light Switches
- SLT Wireless Sensor
- Self-powered Wireless Occupancy Sensor
- More transmitters available

TOOLS NEEDED FOR INSTALLATION:

- Pencil or ballpoint pen
- Electrical Tape
- Power pack (for High Voltage Installation only)

INSTALLATION:

To install the Room Controller select your application from the options below. Follow the instructions for that application. For transmitter installation instructions, see appropriate installation guide(s).

OPTION A:

High Voltage Installation Instructions

- WARNING:** To avoid risk of fire, shock, or death, **TURN OFF POWER** at circuit breaker or fuse and verify that it is OFF before installation begins. Make sure that it remains OFF until installation is complete.
- Read all steps for this option before taking any action to install receiver.
- For in-wall installation, a wiring box must be used. For ceiling installation make wire connections inside a junction box. For best performance install receiver in plastic box away from floor and away from wall niches. Do not install in a location where the temperature exceeds the temperature rating of the receiver (**see "Specifications" for ratings**).
- Connect wires as shown in **Figure A**. Twist wire nuts on clockwise making sure no bare wires show. Wrap connections with electrical tape.
 - Connect the Power Pack relay to the power terminals of the Room Controller using the thin wires protruding from the side of the Power Pack. Observe polarity; the '+' terminal is the first one on the connector block (connect the red wire to the VCC/+ terminal), followed by Ground (connect the black wire to the GND/- terminal).
 - Connect the relay coil (blue wire on Power Pack) to OUT1 of the Room Controller. Additional Power Packs or "slave" or "Add-a-relays" may be connected to other outputs by following the same procedure. Connect all the thin black wires together and to the GND terminal of the 4-Channel Low Voltage Receiver. In these instances, the thin red wires of each additional Power Pack can just be left unconnected since the 4-Channel Low Voltage Receiver already has power. Cap off these wires – DO NOT connect them together!
 - Connect one thick red wire from the top of the Power Pack to the electrical load.
 - Connect the other thick red wire and the thick black wire from the top of the Power Pack to the hot line voltage.
 - (Optional) Connect an occupancy sensor signal to "IN1" wire trap (**WS0RC-300 and WS0RC-200 models only**).
 - Connect the thick white wire from the top of the Power Pack and the neutral wire from the electrical load to the neutral line voltage.
- Restore power and follow programming instructions for appropriate programming mode (**see "Programming" below**). For this installation, Rocker Mode (the default programming mode) is recommended.
- Test receiver (If receiver is not working, review wiring and programming instructions).
- Stow all wires and receiver in wiring box or attach receiver to Power Pack outside of junction box using nylon tie or adhesive tape. Finish any installation of fixture or wall switch.

OPTION B:

Low Voltage Installation Instructions

- WARNING:** To avoid risk of fire, shock, or death, **TURN OFF POWER** at circuit breaker or fuse and verify that it is OFF before installation begins. Make sure that it remains OFF until installation is complete.
- Read all steps for this option before taking any action to install receiver.
- For in-wall installation, a wiring box must be used. For ceiling installation make wire connections inside a junction box. For best performance install receiver in plastic box away from floor and away from wall niches. Do not install in a location where the temperature exceeds the temperature rating of the receiver (**see "Specifications" for ratings**).
- Connect wires as instructed below. Twist wire nuts on clockwise making sure no bare wires show. Wrap connections with electrical tape.
 - Connect power (+) to the VCC wire trap.
 - Connect ground (-) to the GND wire trap.
 - Connect electrical load to the OUT1 wire trap. (Other loads may be connected to outputs 2-4 by repeating **Step C**).
 - (Optional) Connect a sensor signal to the "IN1" wire trap of the receiver.
- Follow steps 5-7 of "**High Voltage Installation Instructions**."

PROGRAMMING

The receiver must be powered when programming. After programming, settings are retained when power is disconnected. The receiver sensitivity is reduced when in Learn Mode to prevent unintentionally associating unwanted transmitters with the receiver. Transmitters should be within 15 feet (5 meters) of the receiver when programming. Program the receiver in any of the modes below.

With a motion detector (wired or wireless) programmed into an output, that output will turn off automatically after a 15 minute timeout with no occupancy detected. After the output turns off, occupancy detected in the next 60 seconds will turn the output back on and restart the 15 minute timeout.

Rocker Mode (default): In Rocker Mode the receiver responds only on a transmitter press and not on the release. For example, one end of the rocker on a wireless light switch will activate the relay (turn the light ON) when pressed and the opposite end of the same rocker will deactivate the relay (turn the light OFF) when pressed. Motion detectors learned in this mode will provide Manual-ON/Auto-OFF operation (CA Title 24 compliant).

Momentary Mode: In Momentary Mode, each end of the rocker on a wireless light switch acts as a separate button. Each end of the rocker programs separately to 1 or more receivers. When a rocker is pressed the output on the receiver will activate (turning the electrical load ON). When the rocker is released the output will deactivate (turning the electrical load OFF). Motion detectors learned in this mode will provide Auto-ON/Auto-OFF operation.

Toggle Mode: In Toggle Mode, each end of the rocker acts as a separate button. Each end of the rocker programs separately. When the rocker is pressed the output of the receiver will always change state (if OFF, it will turn ON; if ON, it will turn OFF). Like Rocker Mode, the output status only changes when a button is pressed and is ignored on the release.

Scene Mode: In Scene Mode, a user can create a preset "scene" with some lights ON and some lights OFF by pressing one button. In Scene Mode, each end of the rocker acts as a separate button. Each end of the rocker programs separately. To create a "scene", a load is set to its desired state, then while in "Scene" programming mode an end of a switch rocker is associated with the receiver or receiver output controlling the load. The desired state for the load will then occur whenever that end of the rocker is pressed. Multiple receivers and/or receiver outputs can be programmed in the same way to the same end of a rocker; this creates a scene that will come up whenever that switch is pressed. Each end of a single rocker can activate a different scene.

Follow the instructions below for the desired programming mode:

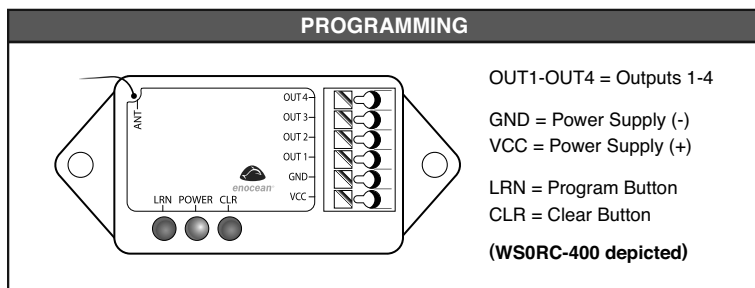

Rocker Mode (default) Programming Instructions

- Read all Rocker Mode programming steps before taking any action to program receiver in Rocker Mode.
- Enter Rocker Mode for Output 1 by pressing and holding the LRN button for 0.5 seconds (**See Figure D**). The electrical load connected to the receiver will begin turning ON and OFF in a slow pattern. Release the LRN button.

- When associating a wireless light switch to the receiver, press one end of a switch rocker (**See Figure E**). When associating a transmitter other than a wireless light switch, press the LEARN button on the Leviton transmitter (**see appropriate transmitter starter guide**). The load will stay ON for about 3 seconds indicating that the receiver has stored the transmitter's unique ID in its memory.
- (If only one transmitter is desired then skip **Step 4** and exit Learn Mode by following **Step 5**). To program a second transmitter to communicate with this receiver, wait until toggling of the load resumes. Repeat the instructions in **Step 3** and **Step 4** until the unique IDs of all desired transmitters are stored in the memory of the receiver (up to 30).
- Enter Learn Mode for Output 2 by briefly pressing and releasing the LRN button. The Power LED will blink twice indicating that Output 2 is in Learn Mode. Output 2 will be in the same programming mode that Output 1 was just in. Additionally, the electrical load connected to output 2 will begin toggling ON and OFF in a slow pattern. Follow **Steps 3 and 4** to program transmitters to Output 2.
- Repeat **Step 5** by followed by **Steps 3 and 4** to program transmitters to Output 3.
- (Optional) Press the TEACH button on a wireless motion detector to associate it with the channel currently being learned. To learn or delete a wired motion detector input to/from an output channel, allow the motion detector to see movement while learning the corresponding output, or toggle the wired motion detector input with a wire. If the wired motion detector input changes while in Programming Mode, the input will be added to or deleted from the output being learned.
- To exit Learn Mode, just wait; the receiver automatically exits Learn Mode after 30 seconds (indicated by the ceasing of the toggling of the electrical load). Alternatively, the LRN button may be pressed for about 2 seconds to exit Learn Mode.

Momentary Mode Programming Instructions

- Read all Rocker Mode programming steps before taking any action to program an output of the receiver in Momentary Mode.
- While the output is in Rocker Mode, press and hold the LRN button for about 3 seconds (**See Figure D**). This activates Momentary Mode for the currently selected output. The electrical load connected to the output will begin toggling ON and OFF in a fast pattern.
- Follow **Steps 3-8** of "**Rocker Mode Programming Instructions**."

Toggle Mode Programming Instructions

- Read all Rocker and Momentary Mode programming steps before taking any action to program an output of the receiver in Toggle Mode.
- While the output is in Momentary Mode, press and hold the LRN button for about 3 seconds (**See Figure D**). This activates Toggle Mode for the output. The electrical load connected to the output will pause briefly, then continue turning ON and OFF in a fast pattern.
- Follow **Steps 3-8** of "**Rocker Mode Programming Instructions**."

Scene Mode Programming Instructions

- Read all Rocker, Momentary, and Toggle Mode programming steps before taking any action to program an output of the receiver in Scene Mode.
- Before programming a "scene", have the desired scene planned out and know the state in which each load will need to be.
- For all loads in the scene that will be ON, program the corresponding receiver or receiver output with a wireless light switch in Rocker Mode. (**Refer to "Rocker Mode Programming Instructions"**).
- Turn ON all of the desired loads that will be ON in the scene.
- For each load in the scene, while the receiver or receiver output connected to the load is in Toggle Mode, press and hold the LRN button for about 3 seconds (**See Figure D**). This activates Scene Mode. The electrical load connected to the receiver or receiver output will pause briefly, then continue turning ON and OFF in a fast pattern.
- For each load in the scene, while the connected receiver or receiver output is in Scene Mode, press the end of a switch rocker that will act as the scene button (**See Figure E**). The load will stay ON for about 3 seconds indicating that the receiver has stored the transmitter's unique ID in its memory.
- For each load in the scene that will be ON, and was programmed in Rocker Mode (**See Step 3 of "Scene Mode Programming Instructions"**), selectively delete the switch from Rocker Mode. While the receiver or receiver output connected to the load is still in Scene Mode, enter into Rocker Mode by pressing and holding the LRN button for about 3 seconds. The load will pause toggling ON and OFF quickly, then resume toggling slowly. Press the associated switch. The load will stay OFF for about 3 seconds, indicating that the receiver has deleted the switch's ID from memory.
- To exit Learn Mode, just wait; the receiver automatically exits Learn Mode after 30 seconds (indicated by the ceasing of the toggling of the electrical load). Alternatively, the LRN button may be pressed for about 2 seconds to exit Learn Mode.

Selective Deleting: Follow the Learn Mode steps above to delete a transmitter from a receiver's memory. Upon pressing the button on the desired transmitter (**See Rocker Mode Programming Instructions, Step 3**) the load will stay OFF for about 3 seconds indicating that the receiver has removed the transmitter's unique ID from its memory. To delete a wired motion detector from the memory, toggle the input while in Learn Mode.

Clear All: If the CLR button is pressed and held for about 2 seconds (**See Figure F**), the entire memory of the receiver will be deleted. The receiver will instantly enter the default programming mode (Rocker Mode) indicated by the electrical load turning ON and OFF. This will delete any motion detectors from memory, and all outputs are restored to Manual-ON/Manual-OFF mode.

Clear One Output Channel: First enter Learn Mode by repeatedly pressing the LRN button until the desired relay's light is blinking. Hold down the clear button for about 2 seconds. This will clear the entire memory for that output, leaving the other outputs intact. This will delete any motion detectors (wired or wireless) from this channel, returning it to Manual-ON/Manual-OFF mode.

ADDITIONAL PROGRAMMING OPTIONS

Inverted Output Mode: The receiver supports the Inverted Output Mode of operation. In the default configuration, the N.O. relay contact is open (not connected) when not active, and closed (connected) when active. When the outputs are in Inverted Output Mode, the N.O. contact is closed when not active and open when active. Inverting the outputs may be used to emulate a normally closed relay that opens when a switch is activated.

One common use for this mode is for magnetic door release controls. The output is ON and the door-hold electromagnet is active until a Momentary switch is activated, deactivating the electromagnet and allowing the door to close. The magnet is reactivated as soon as the switch is released.

Repeater Operation: In order to extend the range of operation in certain environments, Leviton repeaters are available. A repeater re-transmits a copy of every signal received, and many repeaters also function as receivers (The controller models corresponding to this installation guide function as Receiver/Repeaters). It is recommended that no more than two repeaters are active within range of any Leviton transmitter or receiver. Installation of than two repeaters in a single radio domain can degrade the network performance, as radio signal collisions will reduce signal quality.

For best performance, the repeaters(s) should be installed high above the floor in a central location, minimizing the number of walls or other obstructions between the repeater to receive the strongest possible repeated signal. The repeating function of a combination Receiver/Repeater may be deactivated if more than two are inadvertently installed too close to one another.

Inverted Output Mode Programming Instructions

- Turn the power to the receiver OFF.
- Press and hold the CLR button for 5 seconds while turning on the power. The load will blink twice to indicate activation of Inverted Output Mode.
 - To change back to normal operating mode, repeat Steps 1 and 2. The load will blink once to indicate normal (non-Inverted) mode. The state of this mode is stored in non-volatile memory and is maintained even if the power is removed.

Repeater Mode Programming Instructions (controller models only)

To deactivate Repeater Mode:

- Turn power to the repeater OFF.
- While holding down the LRN button turn the power back ON. Continue holding the LRN button for 5 seconds. If Repeater Mode was previously ON, the Output will blink once to indicate that Repeater Mode is now inactive.
 - To turn Repeater Mode back ON, repeat the same procedure. The Output will blink twice to indicate that repeater mode is now turned ON.

These settings are saved in non-volatile memory, and will be maintained even if power is turned OFF and ON.

| | Specifications | | |
|---------------------------|--|------------|------------|
| | WS0RC-400 | WS0RC-300 | WS0RC-200 |
| Range | 50-150 feet | | |
| Frequency | 315 MHz | | |
| Power Supply Input Rating | 8-30 VDC, 40 mA | | |
| Relay Driver | 30 VDC max, 100 mA max | | |
| Repeater | Field configurable | | |
| Channels | 0-in/4-out | 1-in/3-out | 2-in/2-out |
| Operating Temperature | -13° to 140°F (-25° to +60°C) | | |
| Storage Temperature | -40°F to 140°F (-40°F to +60°C) | | |
| Dimensions | 2.88"(W) x 1.30"(H) x 0.67"(D) 7.32cm x 3.30cm x 1.70cm | | |
| Antenna | Attached whip antenna (5.85") | | |
| Vacancy Timeout | 15 minutes (when motion detectors are learned) | | |
| Radio Certification | FCC (United States) SZV-TCM2XXC IC (Canada) 5713A-TCM2XXC | | |

Figure A - Single Pole or Multi-way Wireless Switch (1 or more wireless light switches)

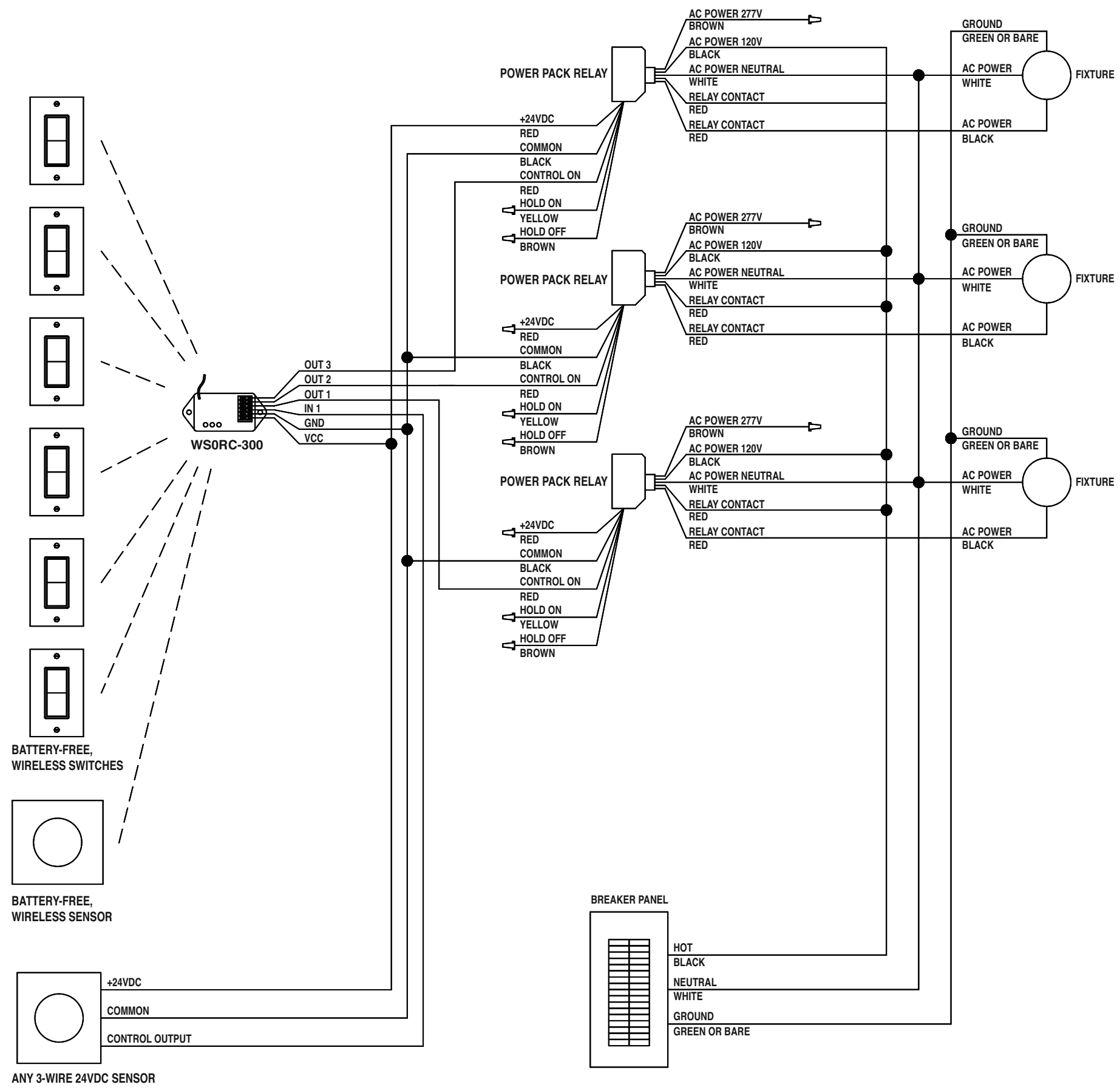

Figure D - Enter Learn Mode

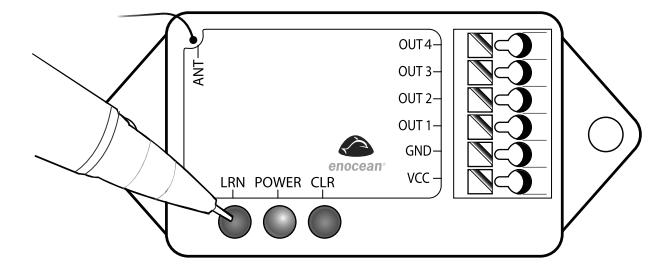

Figure E - Press Transmitter

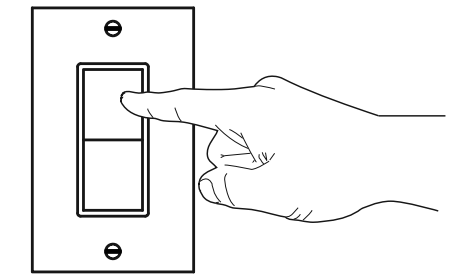
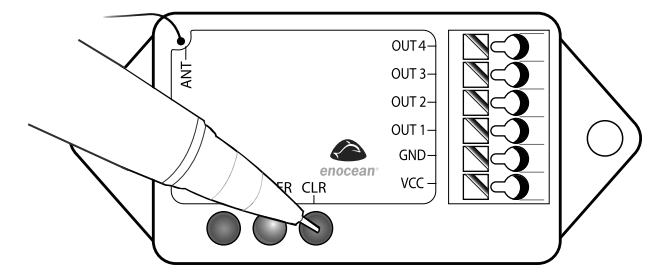

Figure F - Clear All



FCC COMPLIANCE STATEMENT: Contains FCC ID: SZV-TCM2XXC. Contains IC: 5713A-TCM2XXC. The enclosed device complies with Part 15 of the FCC Rules. Operation is subject to the following two conditions: (i.) this device may not cause harmful interference and (ii.) this device must accept any interference received, including interference that may cause undesired operation.

Leviton is a registered trademark of Leviton Mfg. Co. in the United States, Canada, Mexico, and other countries. Other trademarks herein are the property of their respective owners.

LIMITED 2 YEAR WARRANTY AND EXCLUSIONS
 Leviton warrants to the original consumer purchaser and not for the benefit of anyone else that this product at the time of its sale by Leviton is free of defects in materials and workmanship under normal and proper use for two years from the purchase date. Leviton's only obligation is to correct such defects by repair or replacement, at its option, if within such two year period the product is returned prepaid, with proof of purchase date, and a description of the problem to Leviton Manufacturing Co., Inc., Attn: Quality Assurance Department, 201 North Service Road, Melville, New York 11747. This warranty excludes and there is disclaimed liability for labor for removal of this product or reinstallation. This warranty is void if this product is installed improperly or in an improper environment, overloaded, misused, opened, abused, or altered in any manner, or is not used under normal operating conditions or not in accordance with any labels or instructions. **There are no other or implied warranties of any kind, including merchantability and fitness for a particular purpose,** but if any implied warranty is required by the applicable jurisdiction, the duration of any such implied warranty, including merchantability and fitness for a particular purpose, is limited to two years. **Leviton is not liable for incidental, indirect, special, or consequential damages, including without limitation, damage to, or loss of use of, any equipment, lost sales or profits or delay or failure to perform this warranty obligation.** The remedies provided herein are the exclusive remedies under this warranty, whether based on contract, tort or otherwise.

For Technical Assistance Call: 1-800-824-3005 (U.S.A. Only) www.leviton.com