



## DALI Controller (Multi-Location)

Cat. No. CD250

16VDC

Input Current:  
11mA max., less than 1W

For use w/DALI Loop Power Pack

## INSTALLATION INSTRUCTIONS



DI-000-CD250-00A

FEATURES
<ul style="list-style-type: none"> <li>Leviton's Decora® Style design</li> <li>Low-Voltage for easy installation</li> <li>Fits standard wall box</li> <li>One device offers individual, group, and scene control for DALI dimmable ballasts</li> <li>Scene controller conversion face included</li> <li>Multiple controllers can easily be added to the DALI network</li> </ul>
INTRODUCTION
<p>The DALI Controller, Cat No. CD250, allows easy control of fluorescent ballasts supporting the DALI (Digital Addressable Lighting Interface) specification. The DALI controller provides a cost-effective and easy way to control individual ballasts, a group of ballasts, or call scenes. There are two types of operations of the CD250, which are Non-Scene and Scene Control. Within these operations, there are several modes which allow the user great flexibility in how the CD250 is used. The CD250 comes installed with an individual/group controller face and a scene controller face change kit is included.</p>
DESCRIPTION
<p>The DALI Controller has a user-friendly interface. The DALI Controller has two Operations: Non-Scene and Scene operation. Within the Non-Scene Operation, there are the non-scene individual and non-scene group modes. The non-scene individual ON/OFF mode offers control of up to 4 separate DALI compatible ballasts. In this mode, the DALI controller can DIM/BRIGHT up to 4 individual ballasts. On a DALI Network, the user can control up to a maximum of 64 individual ballasts using multiple DALI controllers (CD250). For example, if one controller controls ballasts 1-4, a second CD250 controller can be added and programmed to control ballasts 5-8.</p> <p>When in non-scene group mode, the controller controls up to 4 programmed groups of DALI compatible ballasts. In that group mode, the DALI controller provides ON/OFF and DIM/BRIGHT control for up to 16 groups of DALI compatible ballasts.</p> <p>In Scene operation, the user has the option of either being able to control the DALI compatible ballasts under the scene individual, scene group, or scene broadcast modes. When in scene individual mode, the controller calls programmed "presets" for a single ballast. When in scene group mode, the controller calls "preset" light levels for a group of ballasts. In scene broadcast mode, the DALI controller calls presets for ALL ballasts on that DALI network.</p> <p>The DALI Controller has a removable face to represent the Operation the controller is in. To determine the mode the controller is in, the user must enter the Programming sequence. The programming sequences for the various modes are described under the "PROGRAMMING" section.</p>

FCC COMPLIANCE STATEMENT
<p>This device complies with part 15 of the FCC Rules. Operation is subject to the following two conditions: (1) This device must not cause harmful interference, and (2) This device must accept any interference received, including interference that may cause undesired operation.</p>

### INSTALLATION INSTRUCTIONS

**WARNING:** TO BE INSTALLED AND/OR USED IN ACCORDANCE WITH APPROPRIATE ELECTRICAL CODES AND REGULATIONS.

**WARNING:** IF YOU ARE NOT SURE ABOUT ANY PART OF THESE INSTRUCTIONS, CONSULT A QUALIFIED ELECTRICIAN.

**CAUTION:** DISCONNECT POWER WHEN SERVICING FIXTURE OR CHANGING LAMPS.

**CAUTION:** THE DALI CONTROLLER OPERATES OFF OF LOW-VOLTAGE (16VDC), SO CARE MUST BE TAKEN WHEN REPLACING A LIGHT SWITCH. CONSULT LOCAL BUILDING CODES AND REGULATIONS FOR PROPER LOW-VOLTAGE INSTALLATION.

THE CD250 CAN BE WIRED EITHER AS A CLASS I OR CLASS II WIRING DEVICE. BE SURE TO INSTALL IN THE SAME MANNER AS THE OTHER DEVICES ON THE DALI LOOP. WHEN IN DOUBT, INSTALL AS A CLASS I WIRING DEVICE.

#### TO INSTALL:

- WARNING:** TO AVOID FIRE, SHOCK, OR DEATH; TURN OFF POWER AT CIRCUIT BREAKER OR FUSE AND TEST THAT POWER IS OFF BEFORE WIRING!
- Remove existing wallplate and switch or dimmer, if applicable.  
**CAUTION:** IF APPLICABLE, ENSURE THAT UNUSED CIRCUIT CONDUCTORS ARE PROPERLY CAPPED OFF WITH WIRE CONNECTORS AND REMOVED FROM WALL BOX.
- Connect as per WIRING DIAGRAM. Twist strands of each lead tightly and, with DALI loop wires, push firmly into appropriate wire connector. Screw connectors on clockwise making sure that no bare conductor shows below the wire connectors. Secure each connector with electrical tape.  
**NOTE:** The DALI leads are polarity insensitive.
- Carefully position all wires to provide room in outlet box for DALI controller. Mount DALI controller into box with mounting screws supplied.
- Restore power at circuit breaker or fuse. **INSTALLATION IS COMPLETE.**

### FACE CONVERSION PROCEDURE

The face of this device can be changed to represent the mode the DALI controller is in. Simply replace the ON/OFF face with the scene face on the DALI controller, which is included with the controller (please note that wallplate must be removed).

- Select the face of the mode you desire.
- The frame has snaps on its sides. Using a small screwdriver, gently remove the frame from the strap (refer to Figure 7).
- Take the new frame and position it properly to the strap. Orient the frame so that the ON button/Scene 1 (depending on which face is installed) is the top button. Line up the plastic snaps with the square holes in the strap. Insert the snaps on one side of the frame into the strap.
- Firmly press sideways and down to slip the other snaps into place. The frame snaps in with an audible click. Ensure that all four snaps are secure. Replace Decora® wallplate. **The face conversion is complete.**

### TO OPERATE

**DALI CONTROLLER OPERATION:**  
The functioning of the DALI controller is broken up into two major sections representing the two Operations namely, Scene and Non-scene within which there are: Individual mode, Group Mode, and Broadcast Mode. Refer to Figure 1 for an illustration.

#### A. Non-Scene Operation:

- Individual Mode:** In this mode, the four rows of buttons control four individual ballasts, providing ON/OFF control. Dimming or brightening will only affect one ballast at a time. The DIM/BRIGHT buttons will DIM or BRIGHTEN the last selected ballast. To BRIGHT/DIM another ballast, you must press the button for that row to "activate" that ballast. If control of the same ballast is desired with two different controllers, the corresponding button for that ballast from the second controller needs to be pressed "ON" before Bright/Dim functionality can be used.  
Each row corresponds to a specific address, starting from a base address, which is programmed in the program mode. The address of each row is sequential, starting from the programmed base address. One controller can control only up to four individual ballasts. If control of more than 4 ballasts is required, multiple controllers are needed, with each controller programmed to a different base address. Refer to Table 1A and 1B for details.
- Group Mode:** In this mode, the four rows of buttons control four individual groups, providing ON/OFF control for the entire group of ballasts. The DIM/BRIGHT buttons will DIM or BRIGHTEN the last selected group. Dimming or brightening will only affect one group at a time. Each row corresponds to a specific group number, starting from a base group

number, which is programmed in the program mode. The group number of each row is sequential, starting from the programmed base group number. If multiple controllers are used to control more than 4 ballasts, then each controller must be programmed to a different base group number. Refer to Table 1A and 1B for details.

- NOTES:**
- The LED next to each button will light when that button is pressed, indicating the last action taken. When mixing individual controls with group controls and scene controls on the same DALI loop, the ON/OFF LED indicators may not represent the actual state of the lights.
  - When turning on individual ballast or a group, the lights will turn ON to maximum.

- B. Scene Operation:**
- Scene Mode:** In scene mode, each button calls a specific scene. The scene face on the controller shows scenes 1-7, and Off. The Off scene is displayed on the controller face as a convenience. The default state of all scenes is un-programmed, including Off. All scenes (including Off) must be programmed.
- The LED next to each scene button will light when that button is pressed.
- Scene Mode – Individual:** When the CD250 is in the scene mode, and the individual/group selection is set to individual, the scene controller will call one of 8 presets for the ballast with the same address (*short address*) as the scene controller. The individual ballast can be dimmed or brightened using the DIM/BRIGHT buttons.
  - Scene Mode – Group:** When the CD250 is in scene mode, and the individual/group selection is set to group, the scene controller will call a scene [either 1-8 or 9-16 (scenes 8 and 16 need to be programmed Off)], for the group number programmed. The group can be dimmed or brightened using the DIM/BRIGHT buttons.
  - Scene Mode – Broadcast:** When the CD250 is in scene mode, and the individual/group selection is set to group, AND the Broadcast selection is set, the scene controller will call a scene for ALL groups. All groups can be dimmed or brightened using the DIM/BRIGHT buttons.

#### ADDRESSING AND GROUP IDS:

The DALI ballasts must be assigned addresses. When programming the CD250 to work as an individual controller, the ballasts are given addresses that correspond to the address programmed into the controller. One controller can control up to 4 individual ballasts. To enable this functionality, the CD250 must be programmed with a base address. The base address is used by the CD250 to provide 4 sequential addresses, one for each row of buttons. So if the base address is set to 2, the rows correspond to addresses 2,3,4,5 (from top to bottom).

**Non-Scene Individual Mode:**

When using multiple controllers, the base address of each controller must be programmed. There are 64 individual ballasts allowed on the DALI loop. To control 64 individual ballasts from the CD250, we need to install 16 CD250's (16x4 = 64), and assign a base address to each controller. This means that the range of base addresses is from 0 to 63, and one base address corresponds to 4 DALI addresses. When programming the base address, a number from 0 to 63 must be chosen. From a base address, the CD250 maps rows on each controller to a DALI address. When the programming procedure is finished, each of the ballasts chosen will have an address that corresponds to a particular row. Note that it is possible to have the same ballast controlled by more than one controller depending on what base address is programmed on the devices (refer to Table 1A).

However, the user may opt to address the controllers such that four ballasts are controlled uniquely by one CD250 device and choose not to have overlapping functionality. If this is desired, refer to Table 1A for a description of how base and DALI addressing works in this situation. Note that the DALI addresses will rollover after reaching address 63. The short address will rollover to 0 if the base address is such that rollover is forced (refer to Table 1B).

#### Non-Scene Group Mode

When controlling groups, it is necessary to provide a group ID. There are 16 groups available. To control 16 groups from the CD250, we need to install 4 CD250's, and assign a base group ID to each controller, just like in the case of individual control. The address rollover works the same way in Group mode as in Individual mode described above.

	Base Address/Base Group ID	DALI Address/Group ID
Controller A	0	0
		1
		2
		3
Controller B	1	1
		2
		3
		4
Controller C	2	2
		3
		4
		5

	Base Address/Base Group ID	DALI Address/Group ID
Controller A	0	0
		1
		2
		3
Controller B	1	4
		5
		6
		7
Controller C	2	8
		9
		10
		11
Controller X	62	62
		63
		0
		1

### PROGRAMMING

There are two types of programming for the CD250. There is MODE and address programming, called program mode A (PMA) and DALI setup programming, program mode B (PMB). The programming steps are split into separate operations to simplify programming. PMA is used for programming the MODE of operation and controller base addresses. This is specific to the CD250. PMB is used for mapping the various buttons on the CD250 to different ballasts, and requires interaction over the DALI loop with the ballasts.

To enter the program mode, the program button is used in conjunction with the 8 LEDs located near each of the 8 buttons. The LEDs indicate which of the options are selected, or indicate a binary number relating to an address. Included in this document are matrices of the LED patterns to ease the programming operation.

Addresses are programmed using binary notation, which represents numbers as 0's and 1's. For the programming of addresses, the LED status definitions are:

- Zero → LED blinking
- One → LED continuously lit

The LED definitions for MODE programming will be explained under the appropriate section.

#### Mode and Address Programming (PMA):

To enter mode and address programming, press and release the program button once. All of the LEDs will flash to indicate the controller is now in Program Mode A (PMA). The LEDs corresponding to the address and mode bits set to ONE stay on all the time in this mode. The buttons next to each LED will toggle the state of the LED. The DIM and BRIGHT buttons have no meaning in this mode.

To terminate program mode A, press the program button while in program mode A.

#### DALI Setup Programming (PMB):

Pressing and holding the program button for more than 5 seconds will initialize the DALI setup procedure. This procedure is necessary to address the ballasts and bind them to the certain buttons on the controller. The setup procedure depends on the mode that has been selected. When this setup mode is entered initially, the row of LEDs will blink sequentially (the 'running' lights) to indicate the DALI setup programming mode. They will then blink each column on and off sequentially.

Figure 1 Individual and Group Control

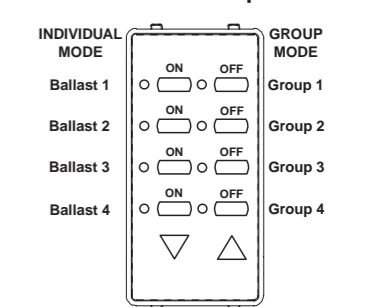

Figure 2 LED callouts for Non-Scene Operation, Individual Mode

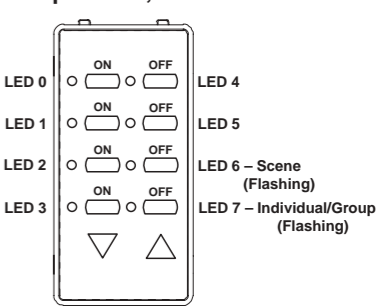

Figure 3 LED callouts for Non-Scene Operation, Group Mode

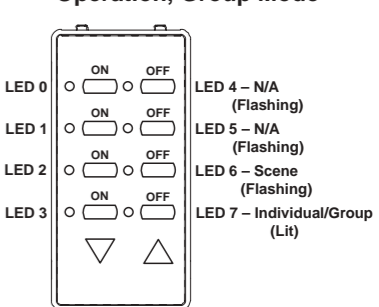
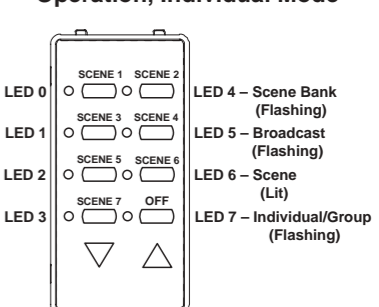

Figure 4 LED callouts for Scene Operation, Individual Mode



**LIMITED 2 YEAR WARRANTY AND EXCLUSIONS**

Leviton warrants to the original consumer purchaser and not for the benefit of anyone else that this product at the time of its sale by Leviton is free of defects in materials and workmanship under normal and proper use for two years from the purchase date. Leviton's only obligation is to correct such defects by repair or replacement, at its option, if within such two year period the product is returned prepaid, with proof of purchase date, and a description of the problem to Leviton Manufacturing Co., Inc., Attn: Quality Assurance Department, 59-25 Little Neck Parkway, Little Neck, New York 11362-2591. This warranty excludes and there is disclaimed liability for labor for removal of this product or reinstallation. This warranty is void if this product is installed improperly or in an improper environment, overloaded, misused, opened, abused, or altered in any manner, or is not used under normal operating conditions or not in accordance with any labels or instructions. There are no other or implied warranties of any kind, including merchantability and fitness for a particular purpose, but if any implied warranty is required by the applicable jurisdiction, the duration of any such implied warranty, including merchantability and fitness for a particular purpose, is limited to two years. Leviton is not liable for incidental, indirect, special, or consequential damages, including without limitation, damage to, or loss of use of, any equipment, lost sales or profits or delay or failure to perform this warranty obligation. The remedies provided herein are the exclusive remedies under this warranty, whether based on contract, tort or otherwise.

For Technical Assistance Call:  
1-800-824-3005 (U.S.A. Only)  
www.leviton.com



DI-000-CD250-00A

**Figure 5**  
LED callouts in Scene Group Mode

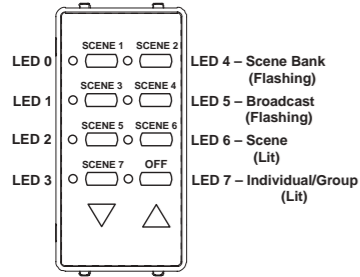

This will indicate the controller is ready to begin programming.

The setup mode can be ended by the following means:

- Successful ending of setup procedure (if there are no more ballasts to find).
- Termination by user by pressing program button during setup procedure.
- After 15 minutes if no actions have been taken.

**RESETTING THE CONTROLLER**

If after switching to the setup mode, the user continues to hold the program button for 10 more seconds, the controller will RESET all devices on the DALI bus to the default values according to the DALI specification. After this the setup and program modes will be terminated. Resetting the controller does not affect the programming or addressing mode that the user may be in.

**PROGRAMMING FOR NON-SCENE OPERATION**

To program a controller, the controller base address and mode of operation need to be programmed using Program Mode A (PMA), followed by mapping the ballasts to the controller using Program Mode B (PMB).

**PMA for Non-Scene Individual Mode:**

To enter mode and address programming, press and release the program button once. All of the LEDs will flash to indicate the controller is now in Program Mode A (PMA). Set LEDs 6 & 7 to flashing (zero) to select non-scene individual control for the device. See **Figure 2** for the meaning of the LEDs in PMA for this mode, for the case when the CD250 is NOT in scene mode, and used as an individual control (LEDs 6 & 7 flashing). After the base address and mode have been set, press and release program button once to exit PMA.

LEDs 0-5 indicate the binary form of the base address for individual mode. To program the Base Address of the controller in Non-Scene Individual Mode, the binary form of the Base Address must be set according to **Table 2** below.

Table 2 – LED state for Base Address							
Address		LED Status					
Base Address	Binary Base Address	LED 5	LED 4	LED 3	LED 2	LED 1	LED 0
0	000000	off	off	off	off	off	off
1	000001	off	off	off	off	off	lit
2	000010	off	off	off	off	lit	off
3	000011	off	off	off	off	lit	lit
4	000100	off	off	off	lit	off	off
5	000101	off	off	off	lit	off	lit
6	000110	off	off	off	lit	lit	off
7	000111	off	off	lit	lit	lit	lit
8	001000	off	off	lit	off	off	off
9	001001	off	off	lit	off	off	lit
10	001010	off	off	lit	off	lit	off
11	001011	off	off	lit	off	lit	lit
12	001100	off	off	lit	lit	lit	off
13	001101	off	off	lit	lit	lit	lit
14	001110	off	off	lit	lit	lit	off
15	001111	off	off	lit	lit	lit	lit
16	010000	off	lit	off	off	off	off
17	010001	off	lit	off	off	off	lit
18	010010	off	lit	off	off	lit	off
19	010011	off	lit	off	off	lit	lit
20	010100	off	lit	off	lit	off	off
21	010101	off	lit	off	lit	off	lit
22	010110	off	lit	off	lit	lit	off
23	010111	off	lit	off	lit	lit	lit
24	011000	off	lit	lit	off	off	off
25	011001	off	lit	lit	off	off	lit
26	011010	off	lit	lit	off	lit	off
27	011011	off	lit	lit	off	lit	lit
28	011100	off	lit	lit	lit	off	off
29	011101	off	lit	lit	lit	off	lit
30	011110	off	lit	lit	lit	lit	off
31	011111	off	lit	lit	lit	lit	lit
32	100000	lit	off	off	off	off	off
33	100001	lit	off	off	off	off	lit
34	100010	lit	off	off	off	lit	off
35	100011	lit	off	off	off	lit	lit
36	100100	lit	off	off	lit	off	off
37	100101	lit	off	off	lit	off	lit
38	100110	lit	off	off	lit	lit	off
39	100111	lit	off	off	lit	lit	lit
40	101000	lit	off	lit	off	off	off
41	101001	lit	off	lit	off	off	lit
42	101010	lit	off	lit	off	lit	off
43	101011	lit	off	lit	off	lit	lit
44	101100	lit	off	lit	lit	off	off
45	101101	lit	off	lit	lit	off	lit
46	101110	lit	off	lit	lit	lit	off
47	101111	lit	off	lit	lit	lit	lit
48	110000	lit	lit	off	off	off	off
49	110001	lit	lit	off	off	off	lit
50	110010	lit	lit	off	off	lit	off

**Figure 6**  
LED callouts in Scene Broadcast Mode

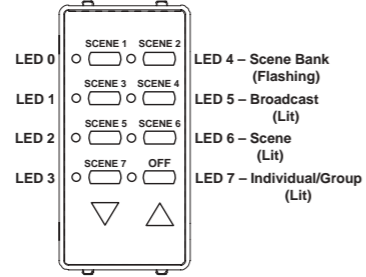

Table 2 – LED state for Base Address							
Address		LED Status					
Base Address	Binary Base Address	LED 5	LED 4	LED 3	LED 2	LED 1	LED 0
51	110011	lit	lit	off	off	lit	lit
52	110100	lit	lit	off	lit	off	off
53	110101	lit	lit	off	lit	off	lit
54	110110	lit	lit	off	lit	lit	lit
55	110111	lit	lit	off	lit	lit	lit
56	111000	lit	lit	lit	off	off	off
57	111001	lit	lit	lit	off	off	lit
58	111010	lit	lit	lit	off	lit	off
59	111011	lit	lit	lit	off	lit	lit
60	111100	lit	lit	lit	lit	lit	off
61	111101	lit	lit	lit	lit	off	lit
62	111110	lit	lit	lit	lit	lit	off
63	111111	lit	lit	lit	lit	lit	lit

**PMB for Non-Scene Individual Mode:**

Pressing and holding the program button for more than 5 seconds will initialize the DALI setup procedure (PMB). Once the PMB is entered, all of the ballasts on this DALI loop will turn on to minimum brightness. At the time the blinking pattern changes from the running lights, to the column blinking, one of the ballasts will turn on to maximum brightness. The CD250 is now ready to program → ready to “map buttons to ballasts”.

If the user wants this particular ballast to be controlled by this controller, the user must choose which button to bind to this ballast by pressing the ON button. **To skip any ballast press any OFF button. Note: The user must press a button, either to bind or to skip.** After this, the controller will proceed to search for the next ballast, and the procedure is repeated. This mode will terminate after controller tries all available ballasts on the bus, or when the user presses the program button one more time to exit the programming mode.

**PMA for Non-Scene Group Mode:**

To enter mode and address programming (PMA), press and release the program button once. All of the LEDs will flash to indicate the controller is now in Program Mode A (PMA). Set LED 6 to flashing (zero) which will place the device in non-scene operation and LED 7 to lit (one) to select non-scene group mode for the device. Refer to **Figure 3** for the meaning of the LEDs in PMA, for the case when the CD250 is NOT in scene mode, and used as a group control (LED 6 flashing, LED 7 lit). LEDs 0-3 indicate the binary form of the base group address for group mode. See **Table 3** for an explanation of the binary numbers for group ID. With group operation selected, LEDs 4 and 5 have no meaning, and will be OFF (flashing).

Table 3 – LED state for Base Address					
Address		LED Status			
Base Address	Binary Base Address	LED 3	LED 2	LED 1	LED 0
0	0000	off	off	off	off
1	0001	off	off	off	lit
2	0010	off	off	lit	off
3	0011	off	off	lit	lit
4	0100	off	lit	off	off
5	0101	off	lit	off	lit
6	0110	off	lit	lit	off
7	0111	off	lit	lit	lit
8	1000	lit	off	off	off
9	1001	lit	off	off	lit
10	1010	lit	off	lit	off
11	1011	lit	off	lit	lit
12	1100	lit	lit	off	off
13	1101	lit	lit	off	lit
14	1110	lit	lit	lit	off
15	1111	lit	lit	lit	lit

**NOTE: Assigning individual ballast addresses must be done in PMB Individual Mode.**

**PMB for Non-Scene Group Mode:**

Pressing and holding the program button for more than 5 seconds will initialize the DALI setup procedure (PMB). Once the PMB is entered, all of the ballasts on this DALI loop will turn on to minimum brightness. At the time the blinking pattern changes from the running lights, to the column blinking, one of the ballasts will turn on to maximum brightness. The CD250 is now ready to program → ready to “map buttons to ballasts”.

The user must decide what groups the selected ballast is to be a part of.

- To include the selected ballast at Maximum to a group, press the corresponding ON button
- To exclude this ballast from the group, press the corresponding OFF button.

The LEDs near each pressed button will stay on after the action (pressing ON or OFF). You have to press all 4 buttons for the selected ballast (either on or off) to continue to the next ballast. That will determine which groups the current ballast will be in. After this, the controller will proceed to search for the next ballast, and so on. The mode will terminate after the controller tries all available ballasts on the bus, or when the user presses the program button one more time to exit the programming mode.

**For Example:**

Consider that you have 4 ballasts on the DALI loop (ballasts A, B, C & D), and you want to control ballasts A & B as a group. Here are the steps.

- Set the base address to 000000, and configure the CD250 for Non-Scene group mode in the PMA.
- Enter the PMB.
- When ballast A turns to max. brightness, press the ON button in the first row (on the CD250). Press the OFF button in rows 2,3 & 4.
- When ballast B turns to max. brightness, press the ON button in the first row (on the CD250). Press the OFF button in rows 2, 3, & 4.

**NOTE:** The ballasts will randomly turn to maximum brightness, and only one will turn to maximum brightness at a time.

When ballasts C & D turn to maximum, press the OFF button in ALL rows.

- This will place ballasts A & B into Group 0 (the first group number of the controller is the same as the set base address of the device).
- The programming mode has ended. The CD250 is ready for operation.

**PROGRAMMING FOR SCENE OPERATION**

**PMA for Scene Individual Mode:**

To enter mode and address programming (PMA), press and release the program button once. All of the LEDs will flash to indicate the controller is now in Program Mode A (PMA). The mode and address programming are different for scene operation than for non-scene operation. When in scene operation, the user must select either individual or group mode. When choosing scene individual mode, the LED meanings are the same as in non-scene individual mode, refer to **Figure 2**. The only, yet critical, difference is that in scene individual mode, the binary address programmed with LEDs 0-5 indicates which ballast to send the preset commands to (*short address*) instead of the controller base address as in non-scene individual mode. To place the controller in Scene operation, set LED 6 to be lit. Set LED 7 to flashing to enter scene individual mode. When in scene operation and the individual mode is chosen, the LED meanings are shown in **Figure 4**.

LEDs 0-3 indicate the scene preset number for the scene to be called for. LED 4 indicates which scene bank is to be used, Scene Bank A (scenes 1-8), or Scene Bank B (scenes 9-16). Scene Bank A is chosen if the LED is flashing.

**PMB for Scene Individual Mode:**

Pressing and holding the program button for more than 5 seconds will initialize the DALI setup procedure (PMB). With the CD250 in scene operation, and the individual mode selected, up to 8 different ballast presets can be programmed for a single ballast. To program, it is useful to have two controllers connected, one to program the presets, and the other to set the light levels.

To program the presets, set one controller to individual control, and program the ballast addresses as done in Non-Scene Operation, Individual Mode. Use this controller to set the preset level for the ballast desired. Put the other controller in scene: individual mode, enter the PMA, and set the controller address to the same ballast which dimming is desired. Now enter the PMB on the scene individual controller, and press the button that is desired to call the preset. The scene individual controller will exit the PMB. Repeat this procedure for all presets desired for the particular ballast.

To program presets for multiple ballasts, the whole procedure must be repeated, using the different ballast addresses desired. For example, if the user wants to call scenes for ballast 0, the scene: individual controller's binary address must be set to 0 in the PMA. If, however, if the user wants to call scenes for ballast 1, the scene individual controller's binary address must be set to 1 in the PMA.

**PMA for Scene Group Mode:**

To enter mode and address programming (PMA), press and release the program button once. All of the LEDs will flash to indicate the controller is now in Program Mode A (PMA). The mode and address programming are different for scene operation than for non-scene operation. When in scene operation, the user must select either individual or group mode. When choosing scene group mode, the LED meanings are the same as in non-scene group mode, refer to **Figure 3**. To place the controller in Scene operation, set LED 6 to be lit. Set LED 7 to be lit to enter scene group mode. When in scene operation and the group mode is chosen, the LED meanings are shown in **Figure 5**.

LEDs 0-3 indicate the scene group number for the scene to be called for. LED 4 indicates which scene bank is to be used, Scene Bank A (scenes 1-8), or Scene Bank B (scenes 9-16). Scene Bank A is chosen if the LED is flashing.

**PMB for Scene Group Mode:**

Pressing and holding the program button for more than 5 seconds will initialize the DALI setup procedure (PMB). With the CD250 in scene operation, and the group mode selected, scenes can be programmed. In this mode, scenes will be called for a particular group. To program, it is useful to have two controllers connected, one to program the individual ballast levels, and the other to set the light levels.

It is important to note that the user must set the light levels for all of the ballasts in a group before the scene can be programmed. It will be useful to create a table that lists the address of all ballasts installed, and to which groups they belong.

When programming more than four ballasts, it is important to program all of the ballasts in the group with an address. This will allow easy setting of the light level for scene programming. This is most important when there are more than 4 ballasts in a group, because only four ballasts can be controlled at a time from a CD250. For example, in order to set the levels for 8 ballasts, first the levels must be set for the first four, the base address on the CD250 changed, and then the light levels set for the second four. And so on for more than 8 ballasts. Again, it is very useful to have the ballast addresses set ahead of time.

To program scenes for ballast groups, set one controller to non-scene group mode and create ballast groups. Use this controller to set the light level for each group of ballasts. (*It may be necessary to change the address of this controller in order to set the light levels for all ballasts in a group*). Put the other controller in scene group mode, and set the controller group number to the group desired. Now enter the PMB on the scene: group controller, and press the scene button to be programmed. The scene: group controller will exit the PMB. Repeat this procedure for all scenes desired for the particular group of ballasts.

**PMA for Scene Broadcast Mode:**

To enter mode and address programming (PMA), press and release the program button once. All of the LEDs will flash to indicate the controller is now in Program Mode A (PMA). To place the controller in Scene operation, set LED 6 to be lit. Set LED 7 to be lit to enter scene group mode. Set LED 5 to be lit to select broadcast mode. Note that broadcast mode will work ONLY when the controller is in scene group mode (LEDs 6 & 7 lit). When the scene broadcast mode is chosen, the LED meanings are shown in **Figure 6**.

LEDs 0-3 indicate the scene group number for the scene to be called for. LED 4 indicates which scene bank is to be used, Scene Bank A (scenes 1-8), or Scene Bank B (scenes 9-16). Scene Bank A is chosen if the LED is flashing. LED 5 indicates broadcast mode. If the LED is lit, then the CD250 is in scene broadcast mode, and the base group ID is ignored. All scenes will be called for on ALL devices on the DALI network.

**PMB for Scene Broadcast Mode:**

Pressing and holding the program button for more than 5 seconds will initialize the DALI setup procedure (PMB). When the CD250 is in scene broadcast mode, the scene controller will call a pre-programmed scene for ALL groups. All groups can be dimmed or brightened using the dim/bright buttons.

**TROUBLESHOOTING**

- If NO LED's are lit; there is no power
    - Check wiring.
  - If LED does NOT light when the button is pressed
    - Check power wiring connections.
- For Multiple DALI controllers on the DALI Network:**
- The DALI controller has power (the LED's light up when pressed) but pressing the buttons have no effect on the lights; there is no communication between the DALI controller and the DALI compatible ballast or the DALI network.
    - If the LED does NOT flash when a button is pressed, see above.
    - If the LED does light up and all wiring is correct, check the base address of the DALI controller and the mode of the DALI controller.

